



Pall Corporation

## HLP6 Hydraulic & Lubricating Oil Purifier

Operation/Service Manual



## **Copyright Clause**

Reprints, even of extracts hereof, are permitted only if the source is quoted and permission has been granted by Pall Corporation. The main components, devices, arrangements, as well as software, control and instrumentation equipment on all of our varnish removal filters are protected both at home and abroad by patent applications, design registrations or copyright.

**Table of Contents**

|           |  |           |
|-----------|--|-----------|
| <b>2</b>  | <b>FOREWORD</b>  | <b>6</b>  |
| <b>3</b>  | <b>SAFETY &amp; GUARANTEE</b>                            | <b>7</b>  |
| <b>4</b>  | <b>SPECIFICATIONS</b>                                    | <b>13</b> |
| <b>5</b>  | <b>INSTALLATION</b>                                      | <b>15</b> |
| <b>6</b>  | <b>OPERATOR INTERFACE</b>                                | <b>19</b> |
| <b>7</b>  | <b>ELECTRICAL CONNECTION</b>                             | <b>21</b> |
| <b>8</b>  | <b>BASIC HLP22 OPERATING PROCEDURES</b>                  | <b>25</b> |
| <b>9</b>  | <b>THEORY OF OPERATION &amp; COMPONENT ID</b>            | <b>37</b> |
| <b>10</b> | <b>MAINTENANCE</b>                                       | <b>39</b> |
|           | 10.1 General Maintenance List                            | 39        |
|           | 10.2 Checking Vacuum Pump Timing Gear Oil                | 40        |
|           | 10.3 Changing Vacuum Pump Timing Gear Oil                | 40        |
|           | 10.4 Replacing Exhaust Coalescer                         | 41        |
|           | 10.5 Replacing Inlet Air Breathers                       | 42        |
|           | 10.6 Cleaning the Inlet Strainer                         | 43        |
|           | 10.7 Replacing the Polishing Filter                      | 44        |
|           | 10.8 Replacing the Demisting Pad                         | 45        |
|           | 10.9 Cleaning Vacuum Pump Cooling Fan                    | 46        |
|           | 10.10 Cleaning Heat Exchanger Vanes                      | 46        |
|           | 10.11 HLP Storage (Two Weeks or More)                    | 47        |
|           | 10.12 Vacuum Pump Filter Cleaning/Replacement            | 47        |
| <b>11</b> | <b>ALARM CONDITIONS &amp; TROUBLESHOOTING</b>            | <b>49</b> |
|           | <u>Major Alarms</u>                                      |           |
|           | 11.1 Major Alarm #1: Phase Reversal / Low / High Voltage | 51        |
|           | 11.2 Major Alarm #2: High System Temperature Shutdown    | 52        |
|           | 11.3 Major Alarm #3: Inlet Pump Motor Contactor Failure  | 54        |
|           | 11.4 Major Alarm #4: Vacuum Pump Motor Contactor Failure | 56        |
|           | 11.5 Major Alarm #5: Inlet Pump Cavitation               | 58        |
|           | 11.6 Major Alarm #6: Change Exhaust Coalescer            | 60        |
|           | 11.7 Major Alarm #7: High Tower Level Shutdown           | 61        |
|           | 11.8 Major Alarm #8: Low Tower Level Shutdown            | 63        |
|           | 11.9 Major Alarm #9: Outlet Pump Motor Drive Overload    | 65        |

|                                      |                                    |                                      |           |
|--------------------------------------|------------------------------------|--------------------------------------|-----------|
| 11.10                                | Major Alarm #10:                   | Inlet Pump Motor Overload            | 66        |
| 11.11                                | Major Alarm #11:                   | Vacuum Pump Motor Overload           | 68        |
| 11.12                                | Major Alarm #12:                   | Dirty Filter Warning / Shutdown      | 70        |
| 11.13                                | Major Alarm #13:                   | Tower Fluid Level Sensor Signal Loss | 72        |
| 11.14                                | Major Alarm #14:                   | Outlet Pump Motor Drive Faults       | 73        |
| 11.15                                | Major Alarm #15:                   | Outlet Pump Motor Drive Comm. Loss   | 74        |
| <br>                                 |                                    |                                      |           |
| <u>Minor Alarms</u>                  |                                    |                                      |           |
| 11.101                               | Minor Alarm #101                   | Heater Thermocouple Signal Loss      | 75        |
| 11.102                               | Minor Alarm #102                   | High Oil Temperature @ Water Sensor  | 77        |
| 11.103                               | Minor Alarm #103                   | High Water Saturation                | 77        |
| 11.104                               | Minor Alarm #104                   | Heater Contactor Failure             | 78        |
| <br>                                 |                                    |                                      |           |
| <u>Warnings</u>                      |                                    |                                      |           |
| 11.201                               | Warning #201:                      | Service Vacuum Pump Soon             | 80        |
| 11.202                               | Warning #202:                      | PLC Battery Low.....Replace Soon     | 80        |
| 11.203                               | Warning #203:                      | Dirty Filter Warning                 | 81        |
| 11.204                               | Warning #204:                      | Not Used                             | 81        |
| 11.205                               | Warning #205:                      | Water Saturation Probe Signal Loss   | 81        |
| 11.206                               | Warning #206                       | Change Exhaust Coalescer Soon        | 82        |
| <br>                                 |                                    |                                      |           |
| <u>Miscellaneous Troubleshooting</u> |                                    |                                      |           |
| 11.301                               | Heater Not Warming the Oil         |                                      | 82        |
| <br>                                 |                                    |                                      |           |
| <b>12</b>                            | <b>HMI SCREENS</b>                 |                                      | <b>83</b> |
| <br>                                 |                                    |                                      |           |
| <b>13</b>                            | <b>SPARE PARTS LIST &amp; MISC</b> |                                      | <b>96</b> |

## 2.0 FOREWORD

This service manual is provided to serve as the installation, operation and maintenance guide for the equipment supplied by Pall Corporation. The contents should be read before attempting any phase of installation, operation and maintenance.

The Pall Corporation HLP6 Hydraulic-Lubricating Oil Purifier requires installation by the customer or prearranged contractor. Unpack carefully and check all items received against the invoice.

The purifier has been tested and quality-controlled in accordance with Pall Corporation standard procedures and also in accordance with the tests specified in the contract when required. However, the equipment as shipped may have been opened or disassembled for draining, cleaning, etc., after testing. The customer should confirm that nuts, bolts, flanges, pipes, closures or any other component have not become loose during shipment; these should be tightened wherever necessary.

An identification tag has been permanently attached to the equipment. If/when requesting information, service or spare parts, please be prepared to furnish the part number and serial number located on the identification tag.

It is the user's responsibility to check actual operating conditions to ensure the filter elements, cartridges, vessel and sealing materials are compatible with the application and are within local safety codes.

Pall reserves the right to modify the contents of this service manual without notification.

### Trademarks & Intellectual Property

Pall,  are trademarks of Pall Corporation.  
*Filtration. Separation. Solution.* is a service mark of Pall Corporation.  
The design of this equipment and all associated documentation is  
copyright of Pall Corporation 2018.

**INTENTIONALLY LEFT BLANK**

### 3.0 SAFETY & GUARANTEE



#### 3.1 General Safety Instructions

It is important that all personnel in charge of installing, setting-up, operating, maintaining or repairing the Oil Purifier and its components read and understand this manual, and, in particular, the section on safety.

Care must be taken when referring to this manual to ensure adherence to all warnings, cautions and important notes. These carry information related to the safety of personnel and the integrity and satisfactory operation of the equipment.

If necessary, in-house instruction should be provided, taking into account the technical qualifications of the personnel concerned.

The following symbols are used in this manual:

|   |   |
|---|---|
|   | <b>WARNINGS: THESE ARE INSTRUCTIONS THAT DRAW ATTENTION TO THE RISK OF INJURY OR DEATH.</b>   |
|  | <b>Cautions: These are instructions that draw attention to the risk of damage to the product, the process, the equipment or the surroundings.</b> |
|  | <b>Important: These are instructions that draw attention to information that will aid installation, operation or maintenance.</b>                 |

## 3.2 Uncrating and Inspection

Prior to uncrating the purifier, inspect the exterior crating for obvious damage that may have occurred during shipment. All damage should be reported to both the freight carrier and Pall Corporation. Obtain the full part number and serial number from the identification tag (shown below) then contact Pall's Technical Support Department at (888) 333-7255 to open a COR.

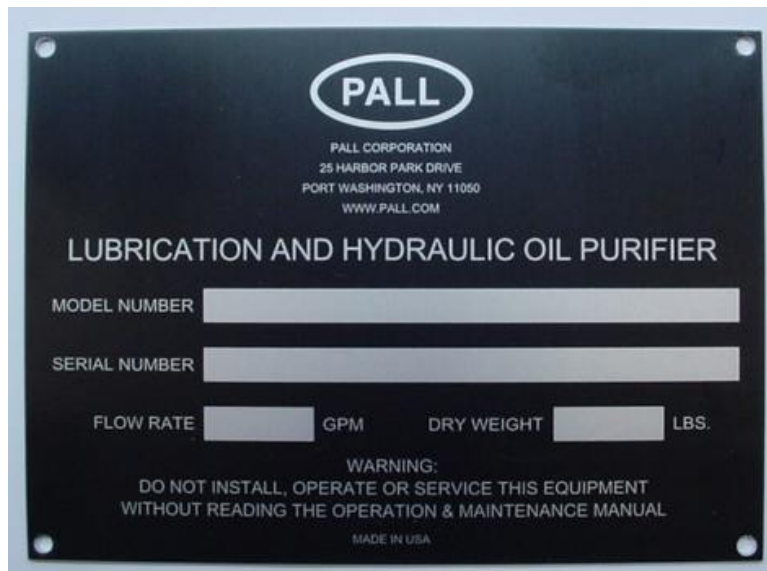

While uncrating the purifier, take care to avoid damaging the wiring of critical electrical and mechanical components.

After removing the purifier from its crate, carefully inspect the skid for damage that may not have been obvious during the initial inspection. It is good practice to ensure all fittings, flanges, nuts, bolts, etc are tight and have not come loose during shipment. Tighten loose items as required.

Pall Corporation recommends the user to completely read through this Operation/Service Manual prior to installing or starting the oil purifier skid. Pall Corporation provides one electronic copy (in CD form) and one printed copy of the Operation/Service Manual. If needed, Pall Corporation can supply additional copies of the Operation/Service Manual's for a nominal fee. Contact your local Pall Corporation representative for a quote.



3.3 Choosing the Installation Site

|   |  |
|---|--|
|  | <p><b>WARNING: EXPLOSION &amp; FIRE HAZARD!</b></p> <p>The purifier is designed for operation in Non-Hazardous environments. When selecting the installation site, ensure that the location is suitable for operating Non-Hazardous rated equipment. If in doubt, check with your plant manager.</p> |
|---|--|

Prior to installing or operating the purifier, consult your safety manager or plant manager regarding the possibility of explosive or flammable gases coming in contact with the oil purifier skid. Do not install or operate the skid in or near environments that contain explosive or flammable gases. Special hazardous environment-rated versions of the purifier are available from Pall Corporation and will be quoted upon request. Contact your local Pall representative for more details.

|  |   |
|--|---|
|  | <p><b>WARNING: TRIPPING HAZARD!</b></p> <p>When choosing the installation site, ensure that all hoses and wires are installed in a manner that doesn't present trip hazards to personnel.</p> |
|--|---|

|   |  |
|---|--|
|  | <p><b>WARNING: DO NOT BLOCK ESCAPE ROUTES!</b></p> <p>Ensure the Oil Purifier does not block designated walkways and escape routes. Consult your plant or safety manager before starting the installation.</p> |
|---|--|

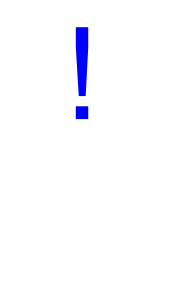
|   |   |
|---|---|
|  | <p><b>Installation Tips!</b></p> <p>The oil purifier skid must be installed on level ground<br/>Allow sufficient/adequate access to all sides of the skid for operating, maintaining and cleaning (Pall recommends 36" clearance on all sides)<br/>Allow adequate overhead clearance to remove service items (review section 10 as well as general arrangement drawing).<br/>Do not place objects in front of or on top of the skid.<br/>Observe all Federal, State, Local and plant regulations.</p> |
|---|---|

3.4 Electrical Safety

|   |  |
|---|--|
|  | <p style="text-align: center;"><b>WARNING - High Voltage!</b></p> <p style="text-align: center;">Lock out &amp; tag out <u>prior</u> to beginning any electrical work.</p> <p>The Oil Purifier skid is powered by high voltage. All safety procedures associated with the operation of the equipment at high voltage must be observed! Lock out and tag out for safety <u>before</u> starting any electrical work!</p> |
|---|--|

|   |  |
|---|--|
|  | <p style="text-align: center;"><b>Warning – Danger to Personnel!</b></p> <p style="text-align: center;">Personal injury may result if the Oil Purifiers safety devices are disconnected or disabled.</p> <ul style="list-style-type: none"><li>• Never disable or dismantle any safety devices.</li><li>• Malfunctions and defects concerning safety devices should be reported immediately to Pall Corporation Technical Support @ 1-888-333-7255.</li><li>• Always shut down, lockout and depressurized the oil purifier skid <u>before</u> starting any electrical or pipe work.</li><li>• Always observe Federal, State, Local and plant safety regulations.</li></ul> |
|---|--|

3.5 Safety of Personnel

Avoid practices which:

- Endanger the health and safety of the user or third parties
- Is detrimental to the health and safety of the operator
- Prevents safe operation of the Oil Purifier
- Does not comply with the Oil Purifier safety instructions

Service and maintenance work for the oil purifier should only be conducted by trained individuals who have read the operation and service manual and are familiar with potential hazards.

**3.6 Training Services**

Pall Corporation offers customized field training services. For more information regarding on-site training, contact your local Pall Corporation representative.

**3.7 Terms of Guarantee**

The Pall Corporation Oil Purifier skid carries a warranty specified within the terms and conditions of the original sale (please refer to Pall Corporation’s standard terms and conditions for exact details).

Pall Corporation is not liable for damage or poor performance resulting from:

- Improper use
- Failure to observe warnings and guidelines in this manual
- Purchase of spare parts from parties other than Pall Corporation or its distributors.
- This includes but is not limited to:

Fluid pumps and motors  
Vacuum pump and motor  
Filter cartridges  
Vacuum pump gear oil

- Employment of insufficiently qualified personnel
- Unauthorized modifications of the Oil Purifier and its components

In these cases Pall Corporation’s warranty/guarantee is rendered void.

|   |   |
|---|---|
|  | <p style="text-align: center;"><b>Caution – Impaired Operation When Using Incorrect Spare Parts!</b></p> <p>Major components such as the fluid pumps, motors, and vacuum pump have been modified by Pall Corporation to work properly with the Oil Purifier. Purchasing these parts directly from the OEM <u>WILL NOT</u> guarantee proper operation.</p> <p>Only use spare parts purchased from Pall Corporation unless otherwise instructed by Pall Corporation or its agent. When using unapproved spare parts, correct operation of the Oil Purifier can no longer be guaranteed.</p> |
|---|---|

**INTENTIONALLY LEFT BLANK**

**4 SPECIFICATIONS**

**4.1 General – HLP6 Oil Purifier**

|                          | Quantity      | Part Number                |
|--------------------------|---------------|----------------------------|
| System Flow Rate         | 6 GPM @ 60 Hz | N/A                        |
| Seals / Elastomers       | N/A           | Fluorocarbon standard      |
| Polishing Filter Element | 1             | UE310A* 20 Z or UE310A*40Z |
|                          |               |                            |

**4.2 Materials of Construction & Piping Codes**

|  |   |
|--|---|
| Wetted Materials                       | Carbon Steel, Stainless Steel, Copper, Brass, Aluminum, Bronze, Fluorocarbon, Teflon, Cast Iron |
| System Electrical Enclosure            | NEMA 4 Painted Carbon Steel   |
| System Piping                          | Stainless Steel Tubing  |
| System Piping Code (HLP10 conforms to) | ANSI B31.1- Power Piping Code<br>ANSI B31.3- Process Piping Code                                |

**4.3 Environmental**

|  |   |
|--|---|
| Design Pressure                          | 150 psig (10.3 Barg)                      |
| Maximum Operating Pressure               | 80 psig (5.5 Barg)                        |
| Ambient Temperature Range                | 39°F (3.9°C) to 105°F (40.6°C)            |
| Maximum Operating Humidity               | 100% RH                                   |
| Long Term Storage Temperature & Humidity | 33 to 120°F (0.5 to 49°C)<br>10 to 85% RH |

**4.4 Utilities**

|  |  |
|--|--|
| Electrical Supply (check purifier name plate)<br>Voltage supplied to the Purifier must be protected with a circuit breaker | 380V-50Hz-3P :: 14.35 FLA :: 9.07 kW<br>480V-60 Hz-3P :: 12.14 FLA :: 9.20 kW<br>575V-60Hz-3P :: 9.53 FLA :: 8.33 kW |
|--|--|

4.5 Weights, Dimensions and Volumes

| Dimensions & Weight | Caster & Floor Mount Model  | Tow Package Model             |
|---------------------|-----------------------------|-------------------------------|
|                     | Width - 32 inches (81 cm)   | Width – 47 inches (120 cm)    |
|                     | Length - 48 inches (122 cm) | Length – 94.5 inches (240 cm) |
|                     | Height - 72 inches (183 cm) | Height – 79 inches (201 cm)   |
|                     | Weight – 1150 lbs (521 Kg)  | Weight – 1244 lbs (565 Kg)    |

4.6 Miscellaneous

|                                    |   |
|------------------------------------|---|
| Inlet / Outlet Connections         | (inlet) 1.5 - inch FNPT<br>(outlet) 1.0 - inch FNPT   |
| Inlet / Outlet Hoses and or Piping | <u>Recommended:</u><br>Inlet - Minimum 1.5 inches ID<br>- Suction-rated hose or pipe<br>- 33 feet (10 m) maximum length<br>- Minimize 90 degree bends/elbows<br><br><u>Recommended:</u><br>Outlet - Minimum 1.0-inch ID<br>- 33 feet (10 m) maximum length<br>- Minimize 90 degree bends/elbows |
| Inlet Pressure Range               | -14”Hg to 10 psig   |
| Maximum Inlet Oil Temperature      | 170°F (76°C)  |
| Maximum Inlet Viscosity            | 4650 SSU (1000 cSt)   |

4.7 Part Numbering Logic

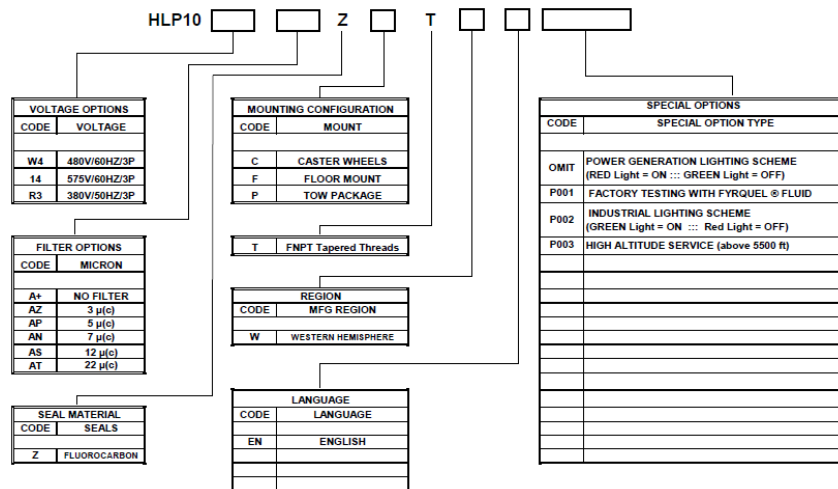

## 5 INSTALLATION

### 5.1 Installation Site Guidelines/Considerations

Before attempting to install the Oil Purifier consider the following:

- Allow for 36 inches of clearance on all four sides of the skid
- Choose a location with cool ambient temperature (105°F [41°C] or less is ideal)
- The Oil Purifier skid should be positioned on the same level as the oil reservoir (inlet pressure range must be within the specifications of section 4.6 and/or the inlet pressure gauge placard located on the gauge cluster). Avoid installing the Oil Purifier below the reservoir, as this may cause flooding.
- The inlet hose/pipe must be suction-rated with a minimum inside diameter of 1.0 inches (2.54 cm).
- The inlet hose/pipe length should not exceed 33 feet (10 m) in length. Avoid 90 degree bends/fittings. Long inlet hose/pipe runs along with 90 degree bends will cause a low pressure in the inlet plumbing and potential difficulty starting the Oil Purifier.

### 5.2 Installation Tips

|   |  |
|---|--|
|  | <h3>Installation Tips!</h3> <p><b><u>SEAL MATERIAL:</u></b> Ensure the purifiers seal material is compatible with the process fluid.</p> <p><b><u>ELECTRICAL SUPPLY:</u></b> Must match the HLP6 electrical requirement.</p> <p><b><u>AVOID HIGH HEAD PRESSURE:</u></b> Limit Head pressure to 10 psi (0.68 bar) or less</p> <p><b><u>ACCESSIBILITY:</u></b> Allow 36 inches of clearance on all four sides of the Oil Purifier</p> <p><b><u>CODES &amp; REGULATIONS:</u></b> Always observe Federal, State, Local and plant regulations</p> |
|---|--|

5.3 Connecting the Purifier to a Fluid Supply

|          |   |
|----------|---|
| <b>!</b> | <b>Caution – Suction Hose Required!</b> |
|----------|---|

When connecting the reservoir to the inlet port of the Oil Purifier it is absolutely critical that **hard piping or a hose rated for suction be used**. Non-suction-rated hoses can collapse internally and restrict the flow of oil to the skid. These internal collapses are often not visible from the outside of the hose. **Use hard piping or suction-rated hose on the inlet!**

|          |  |
|----------|--|
| <b>!</b> | <p><b>Oil Purifier Inlet Plumbing Tips!</b></p> <p><b><u>PIPING:</u></b> Use hard piping wherever possible. Limit the use of 90° bends.</p> <p><b><u>HOSE:</u></b> Inlet hose must be rated for suction.</p> <p><b><u>PIPE/HOSE DIAMETER:</u></b> Inlet plumbing to Purifier must be 1.0" ID minimum</p> <p><b><u>PIPE/HOSE LENGTH:</u></b> Inlet plumbing length should not exceed 33 feet (10 m) unless instructed otherwise by Pall Corporation</p> <p><b><u>ADDITIONAL FITTINGS:</u></b> Remove unneeded fittings minimize leaks &amp; pressure drop</p> |
|----------|--|

**Inlet Plumbing Line Leaks**

Leaks in the inlet plumbing may be difficult to detect due to the low pressure condition inside the inlet line. Drips or fluid loss may not be apparent. Ensure that a minimum number of connections are used and properly tighten all connections. Avoid NPT-type fittings if possible.



**Inlet Line Connection to the Reservoir**

|   |  |
|---|--|
|  | <p><b>Caution – Avoid connecting the Oil Purifier to the very bottom of the reservoir!</b></p> |
|---|--|

Pall Corporation advises not to draw fluid into the Oil Purifier from the very bottom of the reservoir. Although every oil reservoir is different a layer of sludge and or free water may reside at the bottom of the oil reservoir. Ingesting sludge into the Oil Purifier may prematurely plug the inlet strainer and other filters on board the purifier. Free water will not harm the Oil Purifier, but operators are advised to manually drain any free water that may have collected at the bottom of the oil reservoir.

The diagram below is an example of best practice water prevention and monitoring techniques. Pall Corporation recommends plumbing the Oil Purifier as shown. Alternative configurations may be acceptable; check with Pall prior beginning the plumbing project.

**Recommended hookup of Oil Purifier to reservoir**

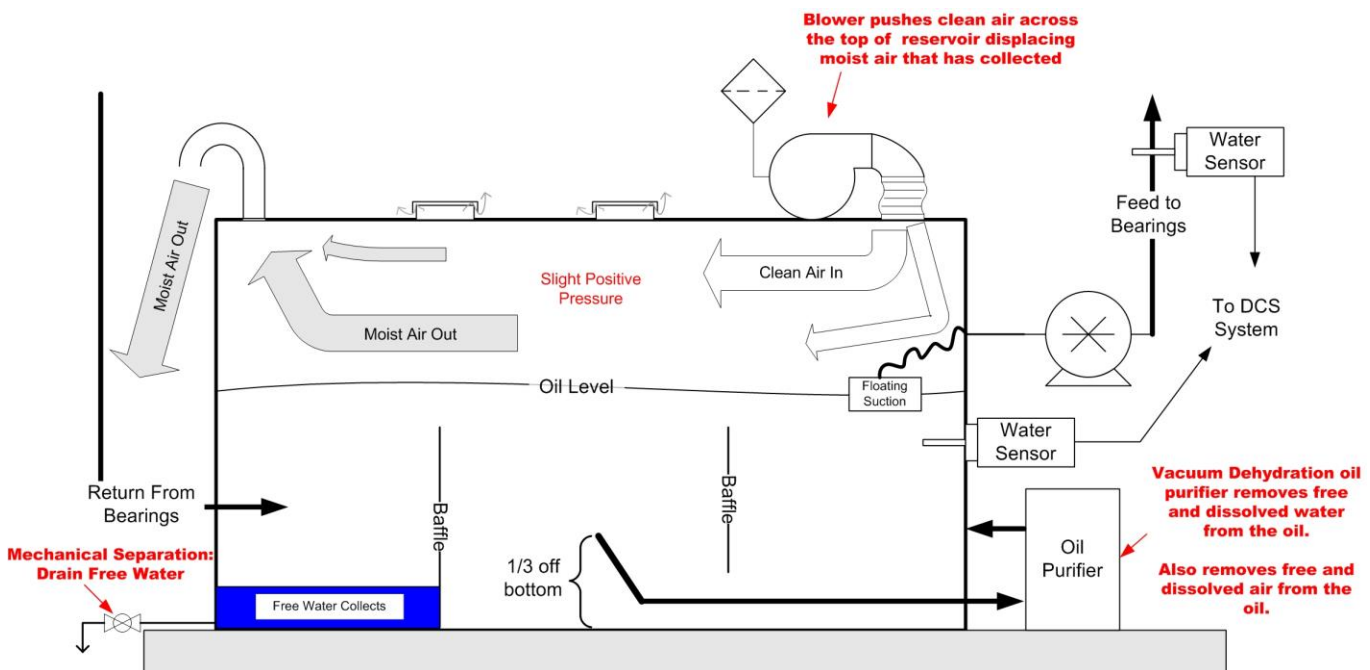

### 5.4 Returning Fluid Back to the Reservoir

Refer to the diagram (above) for general layout plumbing.

Piping/hoses must be rated for 150 PSI (10.3 Bar) operation.

Pipe/hose diameter must be 1" (2.54cm) ID minimum.

Avoid oil splashing; return the oil below the fluid level line on opposite side of reservoir.

The pressure in the line returning fluid from the purifier back to the reservoir should not exceed 60 PSI (4.1 Bar) on the purifiers outlet pressure gauge.

### 5.5 Guide for Hard Plumbing

Elevations, setbacks, and stack tolerances of the ports located on the purifier need to be considered when hard plumbing the purifier. Refer to HLP Arrangement drawing for dimensional details.

## 6 OPERATOR INTERFACE

### 6.1 Controls and Gauges

The front panel is the control center for the Oil Purifier. The control panel and gauge cluster are shown below.

A = HMI (human machine interface)  
 B = Main Disconnect  
 C = Alarm Beacon  
 D = Start Button \*\*  
 E = Stop Button \*\*  
 F = Heater Enable/Disable Switch  
 G = Alarm Reset Button  
 H = Electrical Enclosure Door Locks

\*\* General Industrial or a Power Generation lighting scheme.

Power Generation Lighting Scheme:  
 Red Light = Start or ON  
 Green Light = Stop or Off

General Industrial Lighting Scheme:  
 Green Light = Start or ON  
 Red Light = Stop or Off

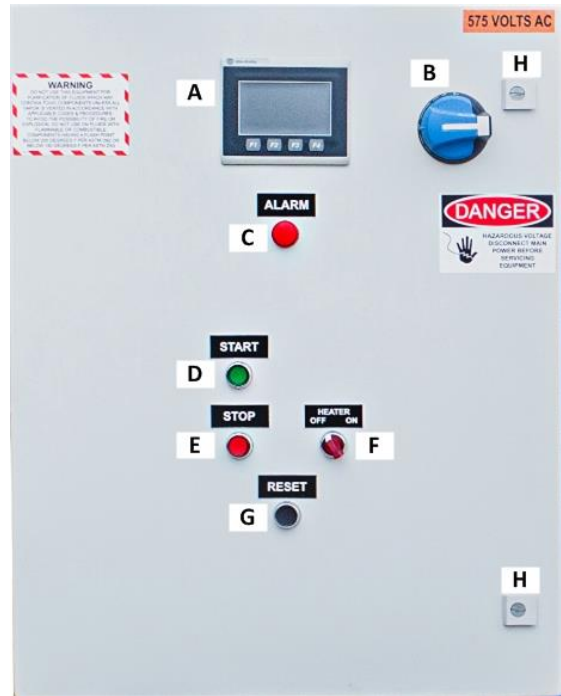



1 = Inlet Pressure  
 2 = Tower Vacuum Gauge  
 3 = Outlet Pressure Gauge  
 4 = Differential Pressure Gauge (polishing filter)  
 6 = Vacuum Pump Backpressure



**INTENTIONALLY LEFT BLANK**

7 ELECTRICAL CONNECTION

|   |   |
|---|---|
|  | <p style="text-align: center;"><b>WARNING - High Voltage!</b></p> <p>Prior to beginning any electrical work, isolate the source voltage supply and locked out and tagged out for safety. The Oil Purifiers electrical panel should not be opened unless the supply voltage is isolated and locked out.</p> <p>The Oil Purifier is to be installed in accordance with the National Electrical Code and all local codes and ordinances. The electricity supplied to the Purifier skid must be ground fault protected.</p> <p>Installation is to be performed by a licensed electrician and inspected by local authorities. Failure to do so could lead to personal injury or death.</p> |
|---|---|

|   |   |
|---|---|
|  | <p style="text-align: center;"><b>WARNING – Verify Supply Voltage!</b></p> <ul style="list-style-type: none"> <li>• The voltage supplied to the Purifier <b><u>must</u></b> be ground fault protected.</li> <li>• Supply voltage must match the design specification!</li> <li>• Match Oil Purifier identification tag and motor identification tag with supply voltage.</li> <li>• Severe motor damage will occur if wrong voltage is supplied.</li> </ul> |
|---|---|

## 7.1 Connecting the Supply Voltage

**Read all cautions and warnings above.**

In order for Pall Corporation to meet the needs of all end-users the Purifier electrical enclosure is not provided with a supply voltage “knock out” port. The end-user must drill a hole in the electrical enclosure for delivery of the supply voltage.

The supply voltage should be connected where shown below. The electrical panel is suitable for WYE configured electrical service only. Contact factory if Delta configuration is desired. The end-user must provide supply voltage with adequate ground fault and circuit breaker protection in accordance with Federal, State, Local and plant regulations.

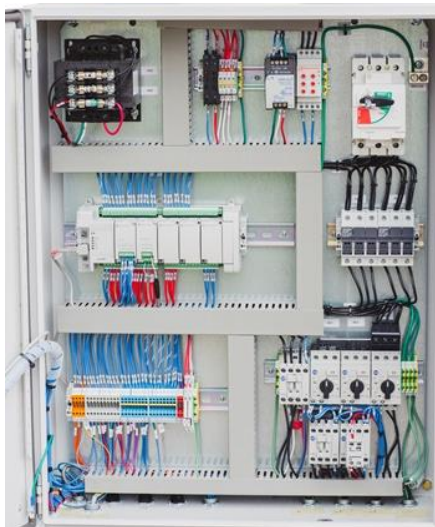

Electrical Enclosure

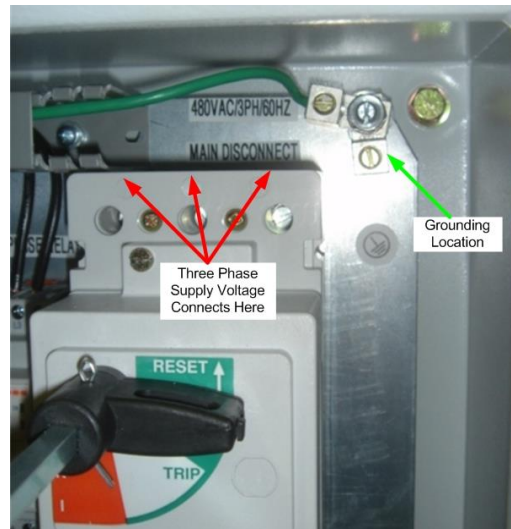

Supply Voltage Termination Points  
(480VAC shown)

## 7.2 Motor Rotation Check

The Purifier will automatically detect if the sequence of the supply voltage has been properly connected. There is no need to bump start the motors to check for rotation. If the supply voltage is out of sequence the purifier will alert the operator with an alarm as shown below. Refer to section 11.1 to correct the situation.

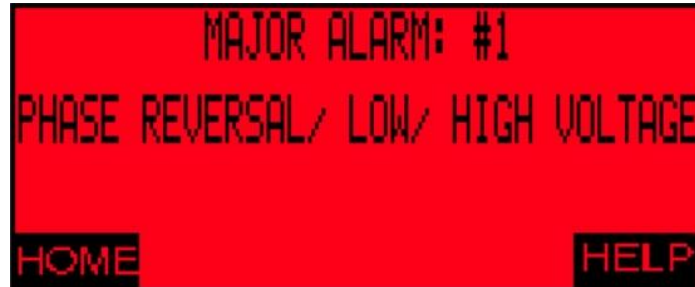

**INTENTIONALLY LEFT BLANK**



## 8 BASIC HLP6 OPERATING PROCEDURES

|   |  |
|---|--|
|  | <p><b>WARNING – Complete sections 5 &amp; 7 First!</b></p> <p>Before proceeding review these sections:</p> <p># 5 INSTALLATION<br/># 7 ELECTRICAL CONNECTION</p> |
|---|--|

### 8.1 Oil Flow Path

During normal operation oil will pass through the Oil Purifier as indicated by the gold arrows. Key system components are identified with numbers which correspond directly to the number found on the hydraulic schematic drawing.

Oil is drawn into the Purifier via the pump/motor group (# 4 / 6). The fluid passes the inlet gate valve (#31) and inlet strainer (#1). Fluid travels through the check valve (#7), dissolved water sensor (#8), heater (#9), and delivered to the vacuum tower (#15). Oil is removed from the vacuum tower via a second pump/motor group (#18&18a). Oil is passed through a polishing filter (#20), check valve (#22) and returned to the oil reservoir.

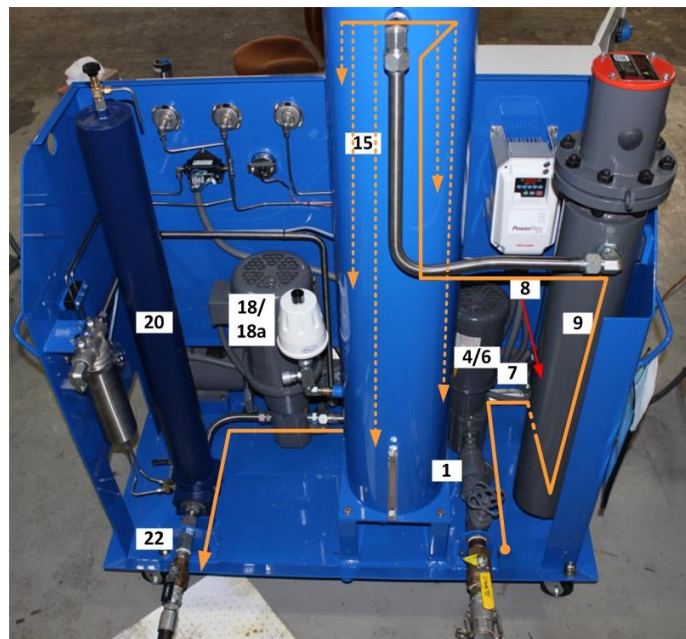

## 8.2 Air Flow Path

When running, the Oil Purifier will maintain a steady flow of air through the vacuum tower. The air flow path is indicated by the yellow arrows. Key system components are identified with numbers corresponding directly to the number found on the hydraulic schematic drawing.

Shortly after starting the Oil Purifier the vacuum pump & motor (#25 & #26) will start and air within the vacuum tower will be exhausted. Ambient air will be drawn into the vacuum tower through the inlet breather filter (#11) and vacuum adjustment valve (#13). Filtered air will travel upwards through the vacuum tower (#15) and into the vacuum pump (# 26). Air leaves the vacuum pump, travels through the heater exchanger (#5), into the coalescer (#29), and exhausts to atmosphere.



## 8.3 Pre-startup Checks

- Check vacuum pump gear oil level (photo below, see maintenance section for oil type and fill procedure)
- Close all drains and vents (locations indicated below).
- Completely open the inlet gate valve (#31).
- Open all valves in the oil supply line to the purifier.
- Open all valves in the oil return line from the purifier to the reservoir.
- Verify condition of inlet air breather (see maintenance section for change-out procedure).

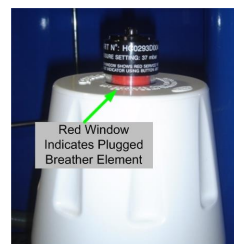
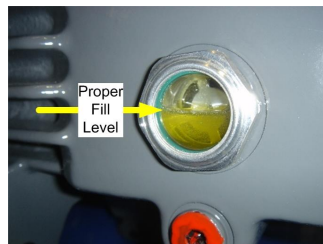
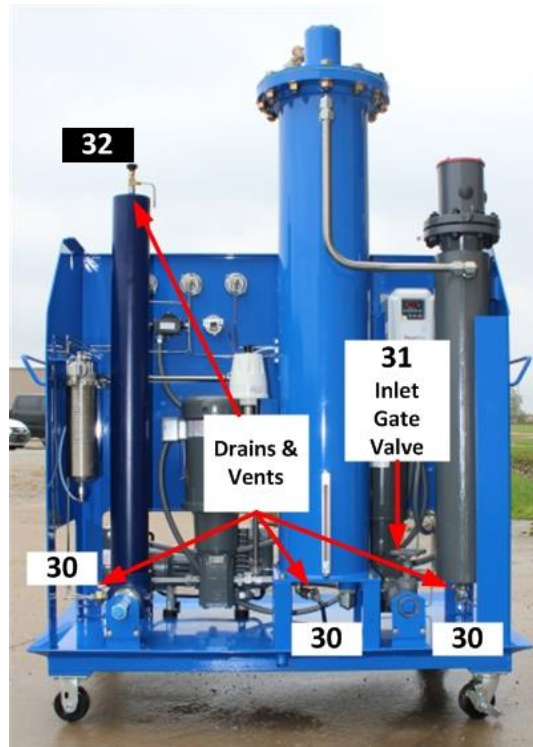

## 8.4 Energizing and Boot-up

Turning the main disconnect to the “ON” position will “boot up” the Oil Purifier. During the boot-up process the HMI will display screens as shown below. When the boot-up process is completed the HMI will display the HOME page with the words “PURIFIER STOPPED READY”.

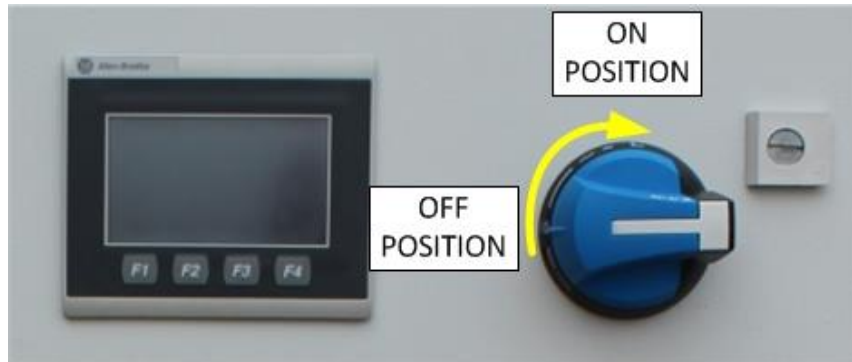

Purifier Booting Up



Purifier Booted Up Ready to Start

**8.5 Starting the Purifier**

Complete sections 7.1, 8.3, & 8.4 first! Ensure all valves connecting the Oil Purifier to the reservoir are 100% open. Only after the Purifier has booted up and the HMI displays “PURIFIER STOPPED READY” can it be started. To start the purifier press the “START” button on the front panel. The start button will illuminate immediately after the start button is pressed. After the purifier starts the HMI screen will display “PURIFIER RUNNING”.

**Special Note about lamp colors:** The Oil Purifier is offered with either a Power Generation lamp coloring scheme or a General Industrial lamp coloring scheme.

**Power Generation Lamp Coloring:**

RED Lamp = Start or Running  
GREEN Lamp = Stop or Off

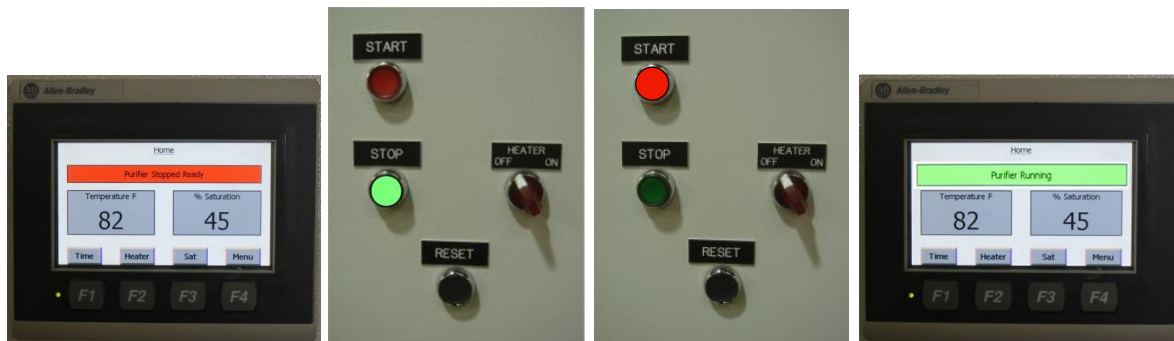

**General Industrial Lamp Coloring:**

GREEN Lamp = Start or Running  
RED Lamp = Stop or Off

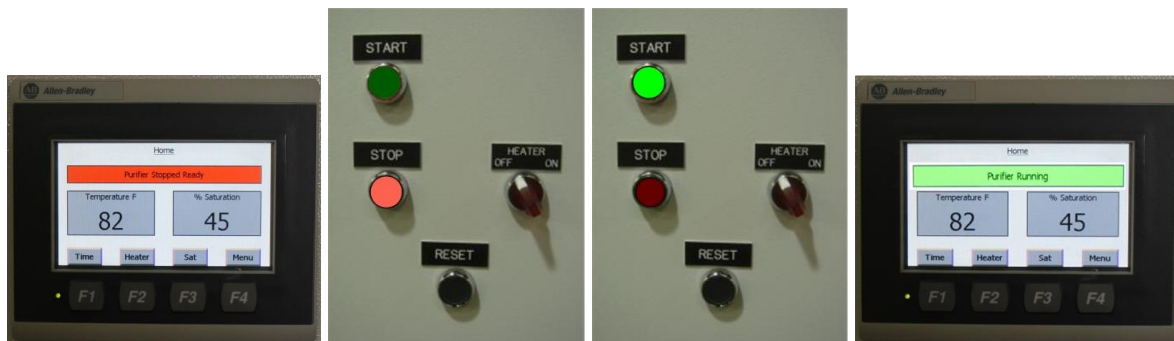

**8.6 Running and Adjusting the Purifier**

A few seconds after pressing the start button the inlet and outlet pumps will start (which one starts first depends on the oil level within the tower). Several seconds later the vacuum pump will start and tower vacuum will begin to build. Oil will be seen rising in the sight glass at the bottom of the vacuum tower. Within 30-60 seconds the oil level within the tower will become stable in the sight glass. Shortly thereafter, if the heater is enabled, it may come on depending on the heaters set point in relation to the current temperature.

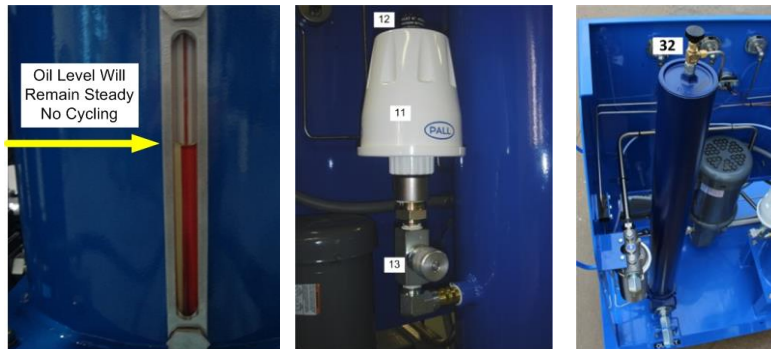

With the purifier running make the following adjustments and observations:

Adjust the tower vacuum to approximately 17-18” Hg using the needle valve (#13). Clockwise rotation of the needle valve will increase tower vacuum. Counter-clockwise rotation will decrease tower vacuum. Note: Adjust the tower vacuum to 16” Hg or less if the water content in the oil is above 100% saturation (see the photo below which indicates where to read the % saturation).

**Caution:** When adjusting the needle valve, use only 1/2-turn (180 degree) or 1/4-turn (90 degree) increments. It may take up to 60 seconds for the tower vacuum to stabilize. Do not over adjust.

Vent air trapped within the polishing filter housing using the needle valve (32).



## 8.7 Gauge Observations

The gauge cluster is shown below. After approximately 60 seconds all gauges should be within the range stated on the placard located below the gauge. If the operator observes a reading outside the stated ranges the Purifier may issue an alarm condition. The operator should turn to the troubleshooting section of this manual for further instructions.



**8.8 Enabling the Heater & Changing Heater Set Point**

The heater is enabled/disabled using the ON/OFF switch located on the front panel. When the heater is enabled the heater logic determines when to energize the heater. **When the heater is energized the switch will illuminate.** When energized the pipe downstream of the heater will feel warmer than the plumbing upstream of the heater. If there is no detectable temperature difference between the upstream and downstream plumbing check the heater fuse bank

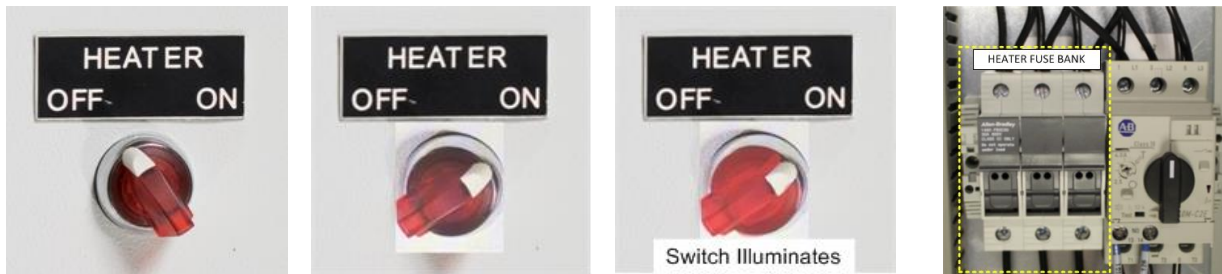

Heater disabled      Enabled, not energized      Enabled & energized      FU1 Fuse Bank

The heater set point is factory set at 120°F (49°C). The set point is adjustable using the purifier’s HMI (human machine interface). The set point can be changed if the purifier is running or not. From the HMI home, page press F2, which corresponds to the heater.



After pressing F2 the operator is taken to the heater control screen (shown below).



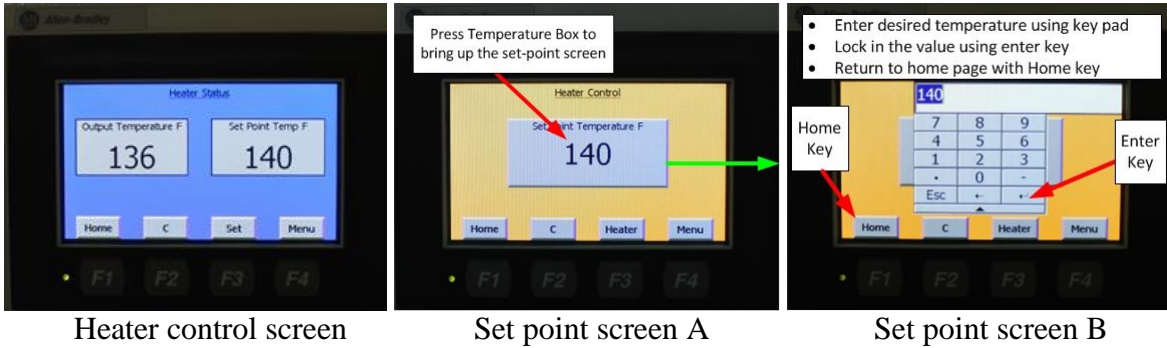

From the heater control screen press F3 to bring up the heater set point screen. Press the temperature box to adjust the heater set point. Heater control is not password protected.

Use the key pad to enter the desired temperature set point.  
 Press enter key to lock in temperature value.  
 Press home key to return to home screen.

Heater Logic: the heater will come on until the setpoint is reached at which time it will turn off. The heater will re-energize when the temperature drops 11°F (6°C) below the setpoint.

**8.9 Cold Startup Condition - Oil Viscosity Above 1000 cSt (4650 SUS)**

The Oil Purifier will not run properly with fluids having a viscosity above 1000 cSt. The user should be aware of cold fluid conditions resulting from hoses laying on cold floors. During colder months of the year, users are advised to drain fluid from purifier supply line hoses when the oil purifier is not being used. It is especially important to keep fluid supply lines to the oil purifier as short as possible to minimize the effects of cold fluid introduction.

**8.10 Stopping the Purifier**

To stop the Purifier press the “stop” button. The heater and all pumps, motors will stop and the stop button will illuminate as shown below.



Power Generation Light Scheme



General Industrial Lighting Scheme

## 8.11 Draining the Purifier

Considerations Prior to Draining: The Oil Purifier is equipped with an automatic draining feature. To maximize the effectiveness of the drain mode, the user should disconnect the fluid supply line from the inlet of the purifier. This will prevent additional fluid from being drawn into the purifier and allow for better drainage overall. If the above-mentioned procedure is followed the purifier will have approximately 1 gallon of fluid still left on board.

If more draining is desired, the user should manually drain the heater, vacuum tower and polishing filter using the manual ball valves located at the bottom of each of these components.

Enabling Drain Mode: The operator should read and understand the section above: titled “Considerations Prior to Draining”.

- To activate the drain mode the purifier must be stopped and the power energized.
- Press and hold the stop button for 5 seconds. After 5 seconds the HMI screen will display the screen below and the user can release the stop button.
- The user can now start the automatic drain mode by pressing the start button. At that time the inlet pump will run for 45 seconds, and the outlet pump for 90 seconds. The operator will see the seconds counting down on the screen.
- The user may also start and stop either the inlet or outlet pump individually. Pressing and holding the F1 key will start the inlet pump; pressing the F4 will start the outlet pump
- When draining is complete, exit to the “Home Page” by pressing F2 (HOME)



**8.12 Crossing Over Between Oil Types**

Situations may arise where the user is switching between two different oil types and minimum cross contamination is required. Below is a guideline for minimizing cross contamination

|   |   |
|---|---|
| 1 | Remove the UE310 filter from its housing and set aside or discard   |
| 2 | Enable automatic drain mode outlined in section 8.11  |
| 3 | Manually drain the heater, tower and filter housing   |
| 4 | Circulate 10-15 gallons of the new fluid through the purifier for 15 minutes, bleed air from the filter housing |
| 5 | Enable automatic drain mode   |
| 6 | Manually drain the heater, tower and filter housing   |
| 7 | Restart the purifier with the new fluid and pump 5-10 gallons of oil to waste                                   |

At this point the purifier will have trace amounts of the original fluid left on board. Even more extensive flushing can be achieved by repeating steps 4, 5, & 6.

**INTENTIONALLY LEFT BLANK**

## 9 THEORY OF OPERATION & COMPONENT IDENTIFICATION

### 9.1 General Claims

The Oil Purifier can be used as a portable or stationary vacuum dehydration unit. It has been designed to purify hydraulic, lubricating, insulating and gear oils by removing water, particulate contamination, and gases.

- Water – 100% of free water, 75% of dissolved water
- Gases – 100% of free & entrained gases, 75% of dissolved gases
- Dirt – including silt and other solids or particulate contaminants.

### 9.2 Theory of Operation

Oil contaminated with water, gas, and particulate is purified on-board the Purifier.

Dry air in the tower is obtained by expansion: Ambient air is drawn into the tower by the vacuum pump, and expanded to approximately 3-4 times its former volume (depending on vacuum set point). As the inlet air volume expands 3-4 fold, the relative humidity of that air decreases 3-4 fold. The resulting air inside the tower has effectively been dried.

The contaminated oil is drawn into the purifier via the inlet fluid pump. The oil passes through the heater and enters the top of the tower. The oil cascades from the top of the tower to the bottom via gravity, passing through a column of stainless steel rings in the process.

While the contaminated oil travels down the column, water trapped in the oil converts from a liquid phase to a gaseous phase. The gasses trapped in the oil will expand as per Boyles Law. As the oil travels down the column the vacuum pump maintains airflow through the tower. Water vapor and expanded gases are removed through the top of the tower by the vacuum pump and are discharged to atmosphere downstream of the vacuum pump.

Dry, degassed oil at the bottom of the tower is drawn out via the fluid pump and passed through the absolute rated filter before returning to the reservoir.

## 9.3 Component Identification

Major Oil Purifier components have been identified below. Not all components have been identified. For more details please refer to the Pall Corporation drawings package enclosed with this operator manual.

### Front View

- A = Gauge Cluster
- B = Electrical Enclosure
- 3 = Inlet Pressure Sensor
- 7 = Inlet Check Valve
- 15 = Vacuum Tower
- 15A = Demisting Pad
- 16 = Fluid Level Sight Glass
- 26 = Vacuum Pump
- 27 = Coalescer Backpressure Sensor
- 28 = Not Used On HLP6



### Rear View

- 1 = Inlet Strainer
- 4 = Inlet Fluid Pump
- 6 = Inlet Pump Motor
- 9 = Heater
- 11 = Inlet Air Breather Element
- 15 = Vacuum Tower
- 18 = Outlet Pump Motor
- 20 = Polishing Filter
- 22 = Check Valve (outlet)
- 24 = Vacuum Pump Relief Valve \*\*
- 29 = Coalescing Filter (air)
- 31 = Inlet Gate Valve
- V = Variable Frequency Drive (VFD) – This item is mounted inside the electrical cabinet on the HLP6 (no shown).

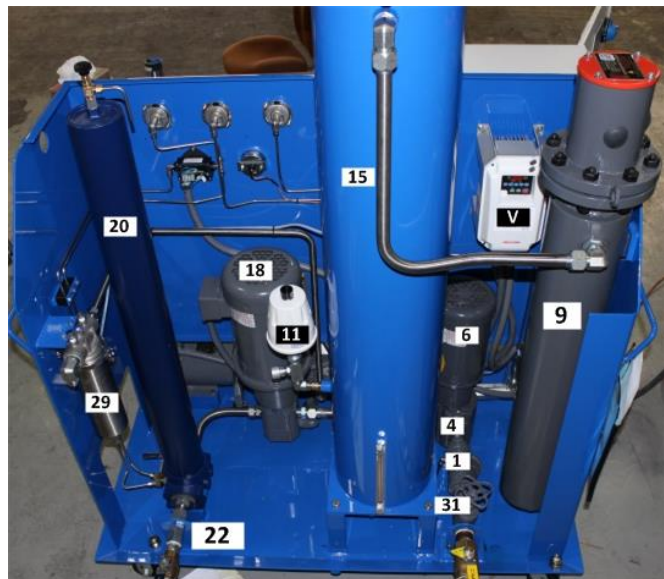

\*\* The vacuum pump relief valve is factory set and should not be adjusted. The valve is properly set by rotating the knob clockwise until the stop is reached. The valve requires no service or adjustment.

10 MAINTENANCE

|   |  |
|---|--|
|  | <p><b>WARNING: No maintenance procedure should be attempted while the purifier is running, with the exception of adjusting the tower vacuum valve.</b></p> <p><b>Prior to starting any maintenance procedure lock out and tag out the Oil Purifier, close the inlet gate valve, and isolate the outlet line.</b></p> |
|---|--|

| <u>MAINTENANCE TYPE</u>               | <u>INTERVAL</u>             | <u>OPS MANUAL SECTION</u> |
|---------------------------------------|-----------------------------|---------------------------|
| Checking Vacuum Pump Timing Gear Oil  | Monthly                     | Section 10.2              |
| Replacing Inlet Air Breather          | Upon Indication             | Section 10.5              |
| Replacing Polishing Filter            | Upon Indication             | Section 10.7              |
| Replacing Exhaust Air Coalescer       | Upon Indication or 4000 hrs | Section 10.4              |
| Replacing Vacuum Pump Timing Gear Oil | Annually                    | Section 10.3              |
| Cleaning Inlet Strainer               | Annually                    | Section 10.6              |
| Replacing Demisting Pad               | Annually                    | Section 10.8              |
| Cleaning Vacuum Pump Cooling Fan      | Annually                    | Section 10.9              |

10.1 General Maintenance List

- Section 10.2 Checking Vacuum Pump Timing Gear Oil
- Section 10.3 Replacing Timing Gear Oil
- Section 10.4 Replacing Exhaust Air Coalescer
- Section 10.5 Replacing Inlet Breather
- Section 10.6 Cleaning Inlet Strainer
- Section 10.7 Replacing Polishing Filter
- Section 10.8 Replacing the Demisting Pad
- Section 10.9 Cleaning Vacuum Pump Cooling Fan
- Section 10.10 Not Used
- Section 10.11 HLP Storage (Two Weeks or More)
- Section 10.12 Vacuum Pump Filter Cleaning/Replacement

### 10.2 Checking Vacuum Pump Timing Gear Oil

The vacuum pump is located on the deck, under the gauge cluster. The timing gear oil level should be checked monthly (proper level shown below). Timing gear oil requires changing after 365 days (8760 hours) of use. See next section for oil type and change-out procedure.

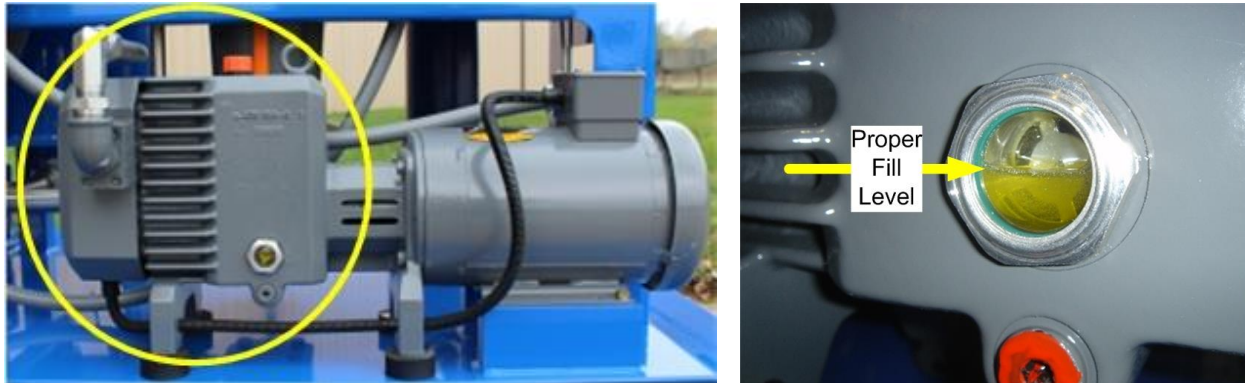

### 10.3 Changing Vacuum Pump Timing Gear Oil

The Oil Purifier will issue a warning in the HMI screen when the vacuum pump timing gear oil requires changing. To view a screen shot of the warning and also view the run-time hours remaining until the warning turn to section 12 of this manual.

Pall Corporation uses only the highest quality oil to lubricate the vacuum pump timing gear. The vacuum pump is shipped from the factory with Jax Syncomp-P ISO 150 oil ([www.jax.com](http://www.jax.com)). Purifier users are encouraged to use the same oil. If alternative oil must be used the oil must meet the following specifications:

Viscosity: ISO 150

Type: PAO (poly alpha olafin) - 100% synthetic

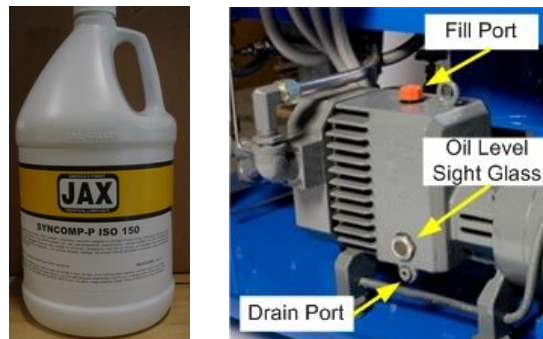



| STEP | ACTION   | COMMENT  |
|------|--|--|
| 1    | Stop the purifier and depressurize                       |  |
| 2    | Lock out for safety                                      |  |
| 3    | Open drain port & oil fill port, drain the oil           |  |
| 4    | Close drain port, Refill with fresh oil, close fill port | <p>Quart size containers of vacuum pump timing gear oil available from Pall p/n 150015001</p> <p>Gallon size available under p/n 150015002</p> |

### 10.4 Replacing Exhaust Coalescer (Vacuum Pump Coalescer)

The Oil Purifier is fitted with an oil vapor coalescer downstream of the vacuum pump. The HMI will alert the operator when changing is required. The coalescer element part number is PFS1001ZMH.

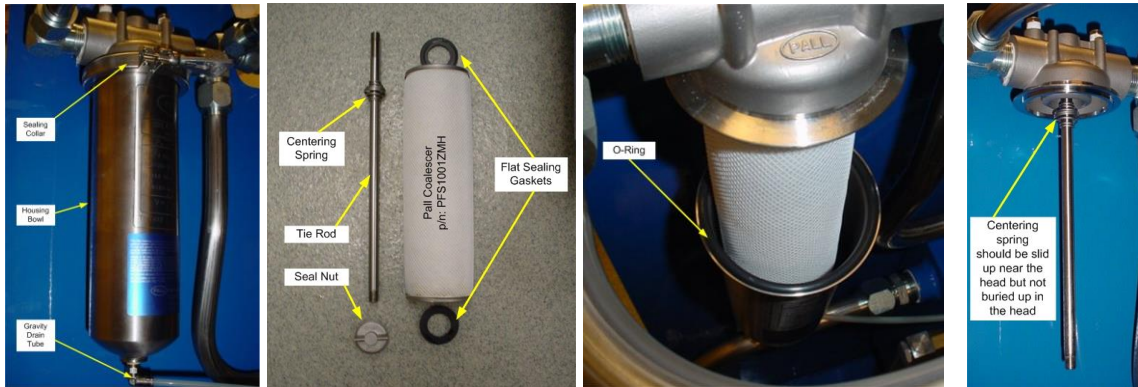

| STEP | ACTION  |
|------|---|
| 1    | Stop the purifier and depressurize                                |
| 2    | Lock out for safety   |
| 3    | Locate the exhaust coalescer, remove the sealing collar and bowl  |
| 4    | Replace the coalescer element p/n PFS1001ZMH                      |
| 5    | Ensure o-ring is in place then re-install bowl and sealing collar |

### 10.5 Replacing Inlet Air Breather

While running, the Oil Purifier introduces filtered air into the vacuum tower through the inlet air breather. The breather is fitted with a visual indicator. The inlet air breather should be changed upon indication.

Note: The HMI screen will not alert the operator when to change the breather; it is the operators responsibility to check the indicator on a regular basis (weekly).

Note: Do not discard the indicator it can be unscrewed and re-used on the new breather filter.

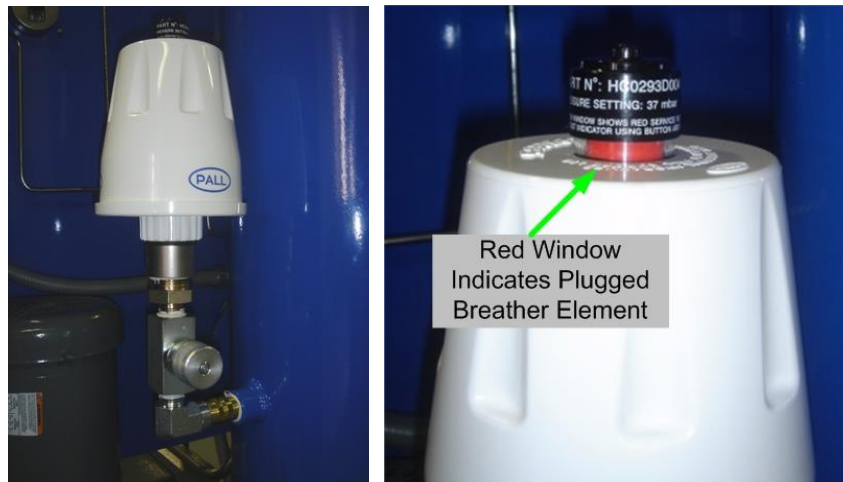

| STEP | ACTION  |
|------|---|
| 1    | Stop the purifier and depressurize                                |
| 2    | Lock out for safety   |
| 3    | Locate the inlet air breather, unscrew by hand                    |
| 4    | Reused the indicator ( part # HC0293D004) on new breather element |
| 5    | Install new breather and hand-tighten only (part # HC0293SEE5)    |

**10.6 Cleaning the Inlet Strainer**

The Oil Purifier is fitted with a strainer to protect the inlet fluid pump. If the inlet strainer becomes blocked a warning will be displayed on the HMI (turn to section 11.5 for details). The inlet strainer should be cleaned and inspected a minimum of 1 time per year.

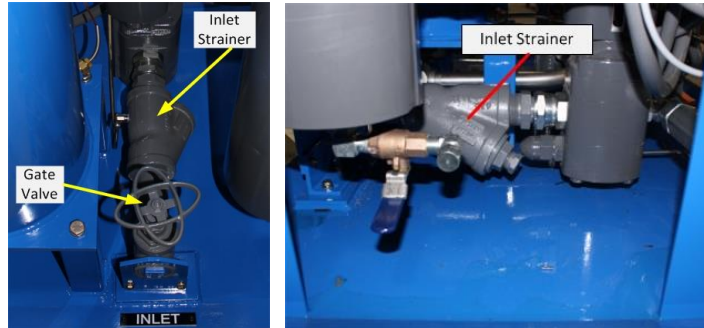

| STEP | ACTION                                 |
|------|--|
| 1    | Stop the purifier and depressurize     |
| 2    | Lock out for safety                    |
| 3    | Close the inlet gate valve             |
| 4    | Remove the “Y” strainer cap            |
| 5    | Remove and clean inlet strainer basket |
| 6    | Re-install strainer and cap            |

### 10.7 Replacing the Polishing Filter Element

The fluid processed by the Oil Purifier is passed through a polishing filter element before returning to the tank or reservoir. If an elevated differential pressure is detected across the filter element the HMI screen will issue a warning (see section 11.12 for details).

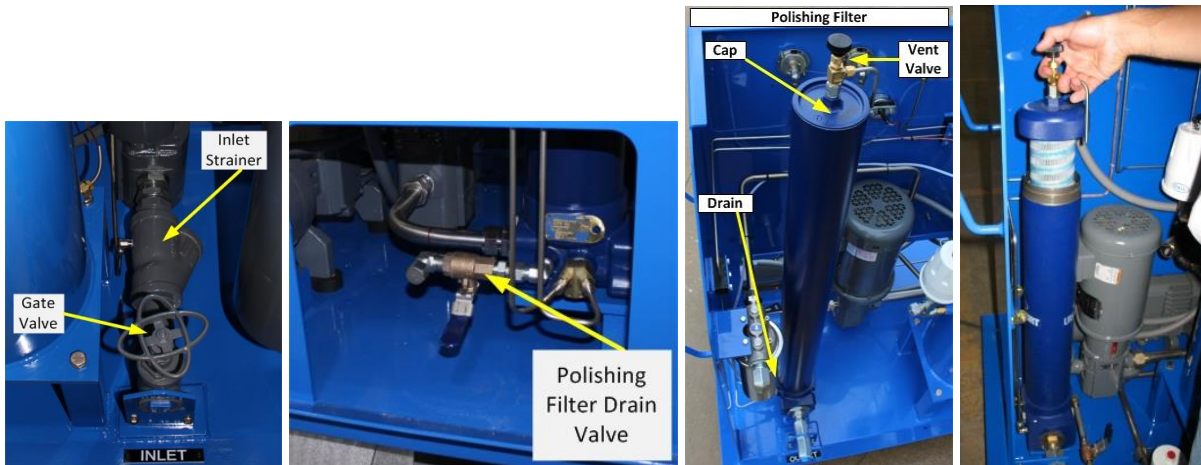

| STEP | ACTION  |
|------|---|
| 1    | Stop the purifier and depressurize  |
| 2    | Lock out for safety   |
| 3    | Close the inlet gate valve  |
| 4    | Open filter housing drain, Open filter housing vent, drain fluid  |
| 5    | Remove filter housing cap and extract filter element  |
| 6    | Wet o-rings of new filter element, install new filter element (check polishing filter housing name plate for filter element part number if not already known) |
| 7    | Re-install filter cap   |
| 8    | Close filter housing drain, Close filter housing vent   |
| 9    | After restarting the purifier remember to vent air from filter housing  |

**10.8 Replacing the Demisting Pad**

The demisting pad located at the top of the vacuum tower should be replaced annually.



| STEP | ACTION  |
|------|---|
| 1    | Stop the purifier and depressurize  |
| 2    | Lock out for safety   |
| 3    | Close the inlet gate valve  |
| 4    | Remove the screws that secure the demister lid (see photo above)  |
| 5    | Obtain Mist Eliminator Kit (contains demisting pad and replacement gasket)<br>HLP6 s/n 1245 and lower :: p/n 150049901<br>HLP6 s/n 1246 and higher :: p/n 100054101 |
| 6    | Using needle-nosed pliers, grab the second ring of the roll (as shown above)  |
| 7    | Pull upwards with steady force to remove the demister   |
| 8    | Install the new demisting pad   |
| 9    | Re-install the sealing gasket, cover and screws   |

**10.9 Cleaning The Vacuum Pump Cooling Fan**

The vacuum pump cooling fan must be annually. Remove the cooling fan shroud as shown below. Clean dust and particulate from the shroud and if necessary clean the fan blades as well. Reinstall the shroud when cleaning is completed.

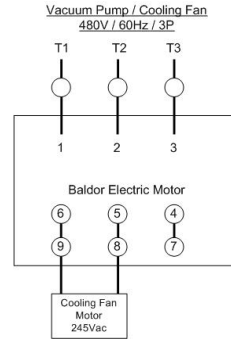
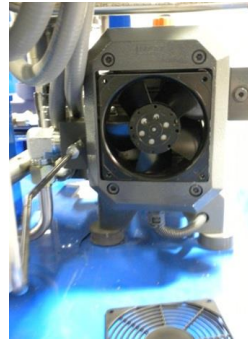

**10.10 Not Used**

**10.11 HLP Storage (Two weeks or more)**

The HLP22 has been design to operate continuously (24/7). If the Purifier is being taken out for service for more than two weeks care should be taken to lubricate the vacuum pump to prevent the possibility of internal corrosion during the storage period. Follow the steps below to lubricate the vacuum pump prior to taking the purifier out of service.



| STEP | ACTION   |
|------|--|
| 1    | Items Needed: 5 mm Allen Wrench :: WD40 Lubricant  |
| 2    | Stop the purifier and depressurize, <u>do not</u> disconnect purifier from the reservoir |
| 3    | Use 5 mm Allen Wrench, remove vacuum pump inlet manifold plug (shown above)              |
| 4    | With the plug removed, restart the purifier, wait for vacuum pump start                  |
| 5    | After vacuum pump starts spray WD40 into the inlet manifold for 3 seconds                |
| 6    | Stop the purifier and depressurize   |
| 7    | Reinstall the vacuum pump inlet manifold plug, purifier can now be stored                |

**10.12 Vacuum Pump Filter Cleaning/Replacement**

The HLP6 vacuum pump is fitted with filter/mufflers to prevent dirt ingress into the pump under high ambient dust/dirt conditions (photo below shows the filter/mufflers installed on the VLR60 vacuum pump). The filter/mufflers are cleanable but can also be replaced if desired.

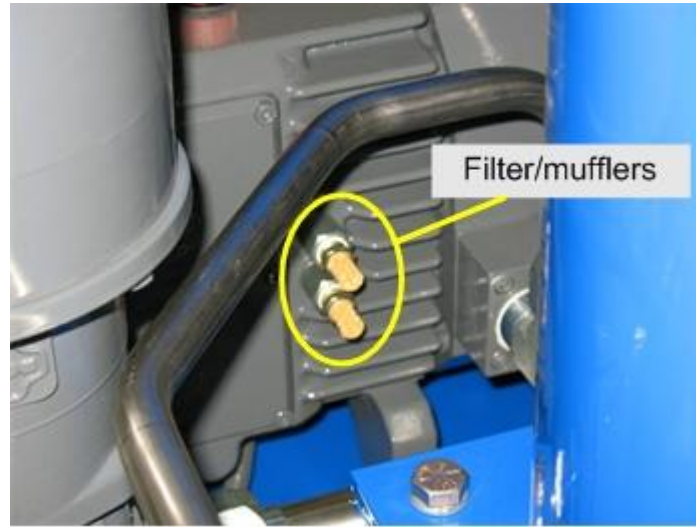

| STEP | ACTION   |
|------|--|
| 1    | Stop the purifier and depressurize, <u>do not</u> disconnect purifier from the reservoir   |
| 2    | Using two appropriately sized wrenches remove the two filter/mufflers.   |
| 3    | Clean the filter/mufflers or if desired replace them with p/n: VLR60BRKIT<br>Kit contains 2 x filter/mufflers and 2 x adaptor fittings |
| 4    | Install filter/mufflers  |
| 5    | Purifier can now be restarted  |

**INTENTIONALLY LEFT BLANK**



## 11 ALARM CONDITIONS, WARNINGS & TROUBLESHOOTING

|   |   |
|---|---|
|  | <p style="text-align: center;"><b>Investigate Alarm/Warning Conditions!</b></p> <p>If an alarm or warning condition occurs the root cause of the condition must be determined to protect the safety of the operator and also the equipment.</p> |
|---|---|

The HMI (human machine interface) located on the front panel of the Oil Purifier will alert the operator of current running conditions and alarm or warning conditions. If a “major” or “minor” alarm condition is detected the HMI will change to a red color and flash a message across the screen. When multiple alarms are present the most recent alarm will be displayed. If a “warning” condition is detected the HMI will turn a brown/yellow color and flash a message across the screen.



### List of Major Alarms

- Section 11.1 Major Alarm #1: Phase Reversal / Low or High Voltage
- Section 11.2 Major Alarm #2: High System Temperature Shutdown
- Section 11.3 Major Alarm #3: Inlet Pump Motor Contactor Failure
- Section 11.4 Major Alarm #4: Vacuum Pump Motor Contactor Failure
- Section 11.5 Major Alarm #5: Inlet Pump Cavitation
- Section 11.6 Major Alarm #6: Change Exhaust Coalescer
- Section 11.7 Major Alarm #7: High Tower Level Shutdown
- Section 11.8 Major Alarm #8: Low Tower Level Shutdown
- Section 11.9 Major Alarm #9: Outlet Pump Motor / Drive Overload
- Section 11.10 Major Alarm #10: Inlet Pump Motor Overload
- Section 11.11 Major Alarm #11: Vacuum Pump Motor Overload
- Section 11.12 Major Alarm #12: Dirty Filter Warning / Shutdown
- Section 11.13 Major Alarm #13: Tower Fluid Level Sensor Signal Loss
- Section 11.14 Major Alarm #14: Outlet Pump Motor Drive Fault <###>
- Section 11.15 Major Alarm #15: Outlet Pump Motor Drive Comm.Loss

## List of Minor Alarms

- Section 11.101 Minor Alarm #101: Heater Thermocouple Signal Loss
- Section 11.102 Minor Alarm #102: High Oil Temperature at Water Sensor
- Section 11.103 Minor Alarm #103: High Water Saturation
- Section 11.104 Minor Alarm #104: Heater Contactor Failure

## List of Warnings

- Section 11.201 Warning #201: Service Vacuum Pump Soon
- Section 11.202 Warning #202: PLC Battery Low....Replace Soon
- Section 11.203 Warning #203: Dirty Filter
- Section 11.204: Warning #204: Not used
- Section 11.205: Warning #205: Water Saturation Probe Signal Loss
- Section 11.206: Warning #206: Change Vacuum Pump Exhaust Coalescer Soon

## Troubleshooting

Section 11.301          Heater Not Warming the Oil

11.1 Major Alarm #1: Phase Reversal / Low / High Voltage

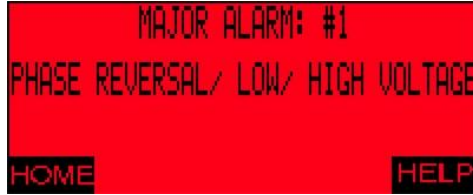

The HMI will display “PHASE REVERSAL/LOW/HIGH VOLTAGE” when supply voltage is out of expected range. Listed below are the 4 possible causes for this alarm. The HMI does not identify which of the 4 conditions is causing the alarm, only that an alarm condition exists.

- Phase Reversal – supply voltage is out of phase, switch 2 of 3 supply voltage legs.
- Phase Loss – one or more of the supply voltage legs is not energized
- Low Voltage – the voltage supplied to the purifier is below the lower threshold.
- High Voltage – the voltage supplied to the purifier is above the upper threshold.

To determine which of the 4 possibilities is causing the alarm the operator must open the electrical panel and view the lights on the sensor.

Also check the FU6 fuse bank for any blown fuses.

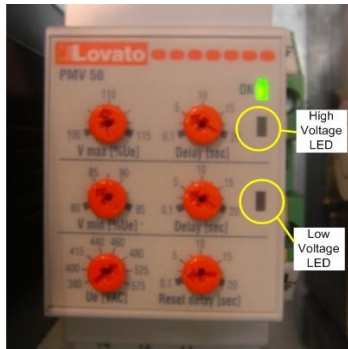

Explanation of LED Light Sequences

Normal Operation – Green LED on & Red LED's off

Phase Reversal – Alternating flashing of Green & Red LED's

Low Voltage – Green LED flashing & Red Low Voltage LED on

High Voltage – Green LED flashing & Red High Voltage LED on

Phase Loss – Green LED flashing

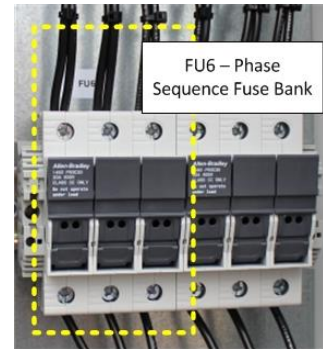

|  |  |
|--|--|
|  | <p><b>WARNING – Do Not Adjust Supply Voltage Sensor!</b></p> <p>The sensor is designed to protect the Oil Purifier from damage caused by fluctuating supply voltage conditions. The sensor is factory set and should not be adjusted unless instructed to do so by Pall Corporation. <u>Adjusting the sensor outside of the factory set points will void the Oil Purifiers warranty.</u></p> |
|--|--|

**11.2 Major Alarm #2: High System Temperature Shutdown**



When the HLP Oil Purifier detects a temperature  $\geq 180^{\circ}\text{F}$  ( $82^{\circ}\text{C}$ ) the “HIGH SYSTEM TEMPERATURE SHUTDOWN” alarm will be shown on the HMI screen and the purifier will shutdown.

|   |  |
|---|--|
|  | <p><b>Operational Tip!</b></p> <p>High temperature alarms may occur during the initial installation of the purifier or if the purifier is being moved to a new location. The root cause is usually unstable oil flow due to air in the supply lines. Operators are advised to turn the heater off until the purifier has demonstrated it can run stable.</p> |
|---|--|

| Probable Alarm Causes  | Solutions   |
|--|---|
| The oil delivered to the purifier is $\geq 180^{\circ}\text{F}$ ( $82^{\circ}\text{C}$ ) | Oil within the reservoir or tank should be cooled below $160^{\circ}\text{F}$ ( $71^{\circ}\text{C}$ ). |
| Thermocouple short-circuited or damaged  | Follow flow chart below   |
| Damaged thermocouple signal conditioner  | Contact Pall Corporation  |

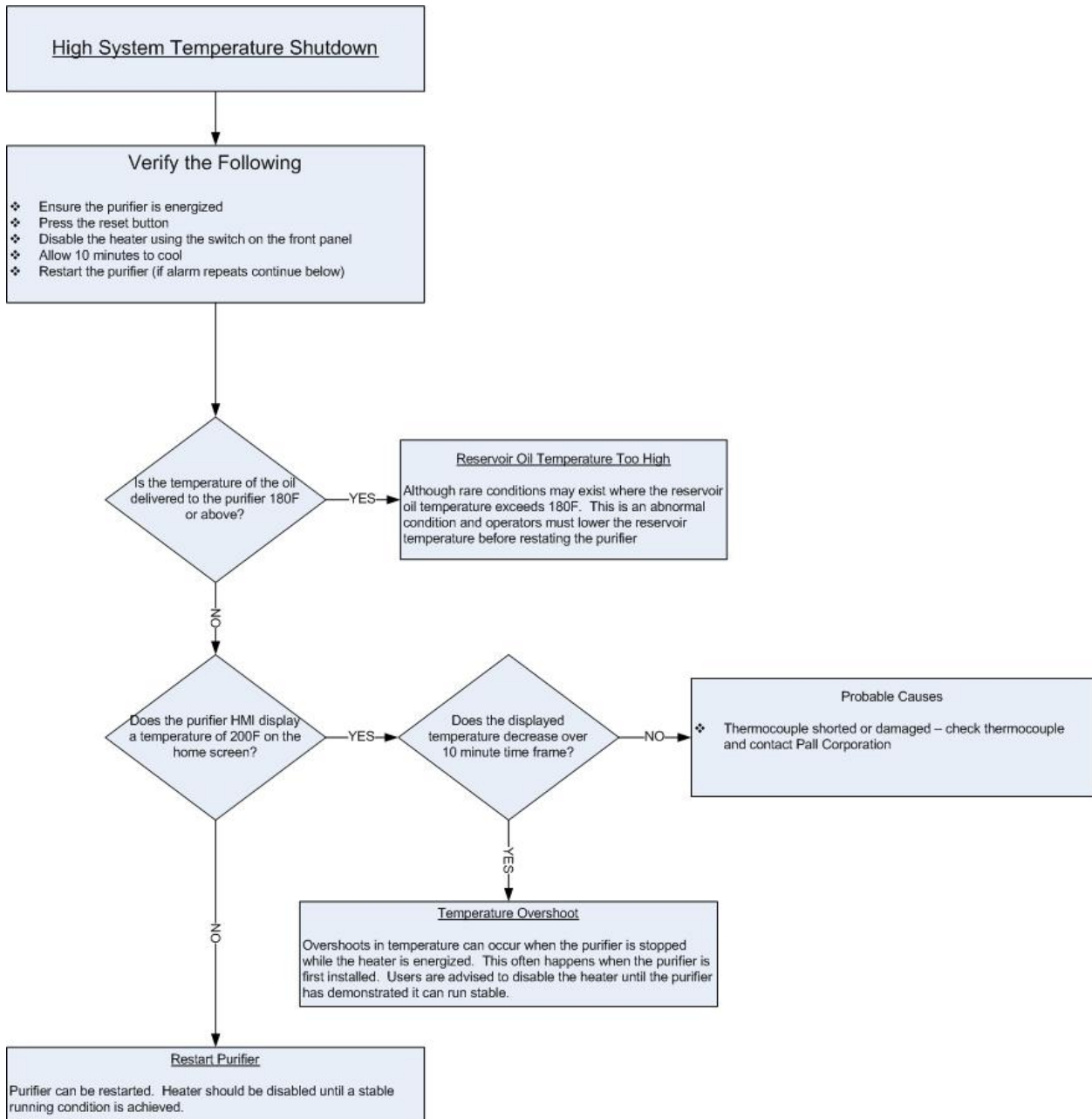

11.3 Major Alarm #3: Inlet Pump Motor Contactor Failure



The contactor for the inlet fluid pump motor of the Oil Purifier is monitored for proper operation at all times. Whenever the inlet fluid pump motor is engaged the PLC monitors input IO6 (wire #120) for a 24 VDC acknowledgement signal. If the signal differs from what is expected the “INLET PUMP MOTOR CONTACTOR FAILURE” alarm will be announced on the HMI screen and the purifier will shutdown.

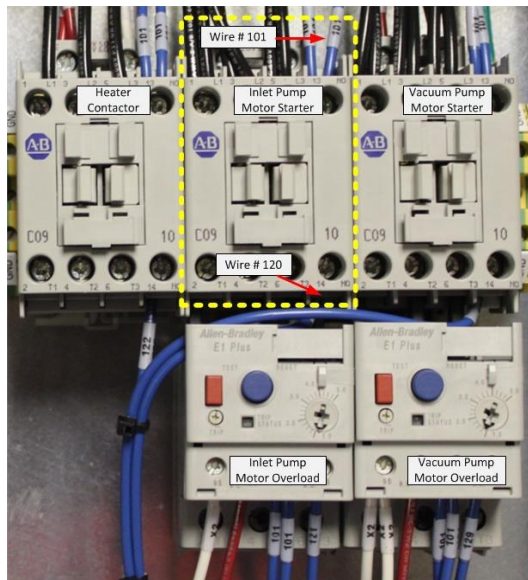

Inlet Pump Motor Contactor



24 VDC Power Supply

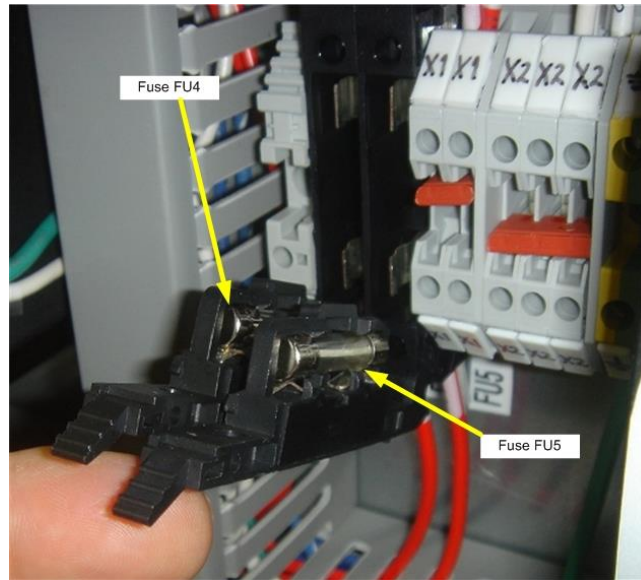

| STEP | ACTION  |
|------|---|
| 1    | Stop the purifier and depressurize  |
| 2    | Lock out for safety   |
| 3    | Verify the integrity of Fuse FU4, replace if needed.  |
| 4    | Test and repair continuity of wire #120 from the contactor (shown above) and input IO6 at the PLC. Wire should be continuous, repair as needed.   |
| 5    | Manually press in the contactor, simultaneously test continuity of wire #120 & #101 (shown above). Circuit should be continuous when contactor is pressed in. Replace contactor if continuity test fails. |
| 6    | Test and repair the continuity of wire #101 at the contactor and wire #101 at the 24VDC supply.   |
| 7    | After completing the above, energize the purifier but do not start. Carefully verify 24 VDC on wire #101 at the inlet motor contactor. Replace the 24 VDC supply if no voltage is detected.               |
| 8    | Re-start the purifier   |

11.4 Major Alarm #4: Vacuum Pump Motor Contactor Failure



The contactor for the vacuum pump motor of the Oil Purifier is monitored for proper operation at all times. Whenever the vacuum pump motor is engaged the PLC monitors input I14 (wire # 128) for a 24 VDC acknowledgement signal. If the signal differs from what is expected the “VACUUM PUMP MOTOR CONTACTOR FAILURE” alarm will be announced on the HMI screen and the purifier will shutdown.

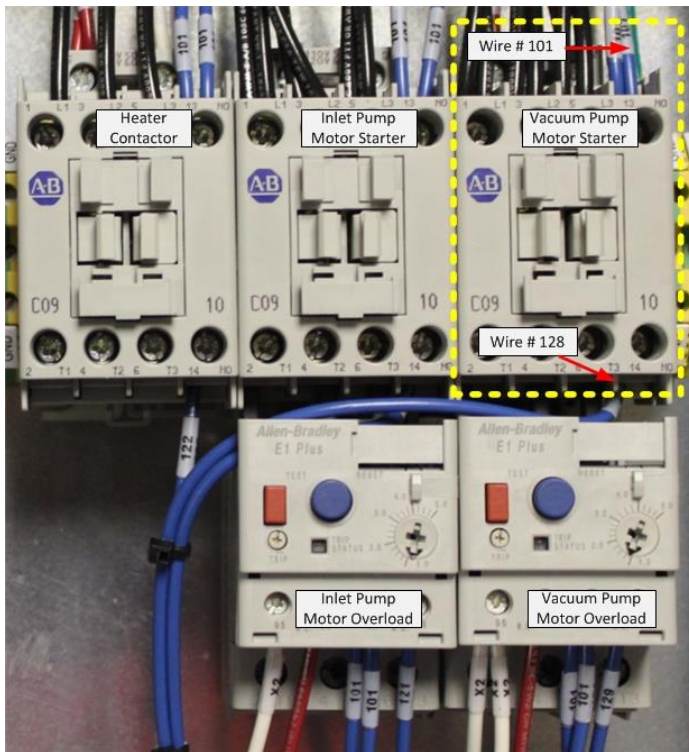

Vacuum Pump Motor Contactor



24 VDC Power Supply



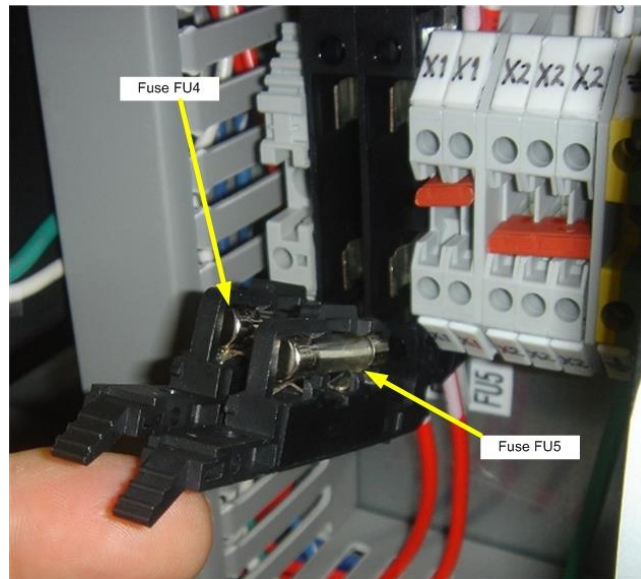

| STEP | ACTION  |
|------|---|
| 1    | Stop the purifier and depressurize  |
| 2    | Lock out for safety   |
| 3    | Verify the integrity of Fuse FU4, replace if needed.  |
| 4    | Test and repair continuity of wire #128 from the contactor (shown above) and input I14 at the PLC. Wire should be continuous, repair as needed.   |
| 5    | Manually press in the contactor, simultaneously test continuity of wire #128 & #101 (shown above). Circuit should be continuous when contactor is pressed in. Replace contactor if continuity test fails. |
| 6    | Test and repair the continuity of wire #3 at the contactor and wire #101 at the 24VDC supply.   |
| 7    | After completing the above, energize the purifier but do not start. Carefully verify 24 VDC on wire #101 at the inlet motor contactor. Replace the 24 VDC supply if no voltage is detected.               |
| 8    | Re-start the purifier   |

## 11.5 Major Alarm #5: Inlet Pump Cavitation

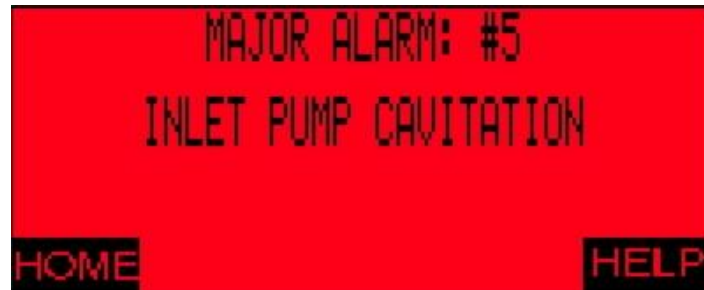

Low pressure upstream of the inlet pump (often called Pump Cavitation) may damage the inlet fluid pump. The Oil Purifier is equipped with a pressure sensor upstream of the inlet fluid pump to monitor inlet line pressure. When a low pressure is detected the HMI will display “INLET PUMP CAVITATION” and the purifier will shutdown.

Possible causes of this alarm are:

- Closed valve in the fluid supply line to the purifier
- Obstruction within the fluid supply line
- Cold oil (high viscosity) in the fluid supply line
- Clogged purifier inlet strainer
- Collapsed fluid supply line (hoses not rated for suction may experience this)
- Faulty inlet suction switch

Use the flow chart on the next page to troubleshoot this alarm.

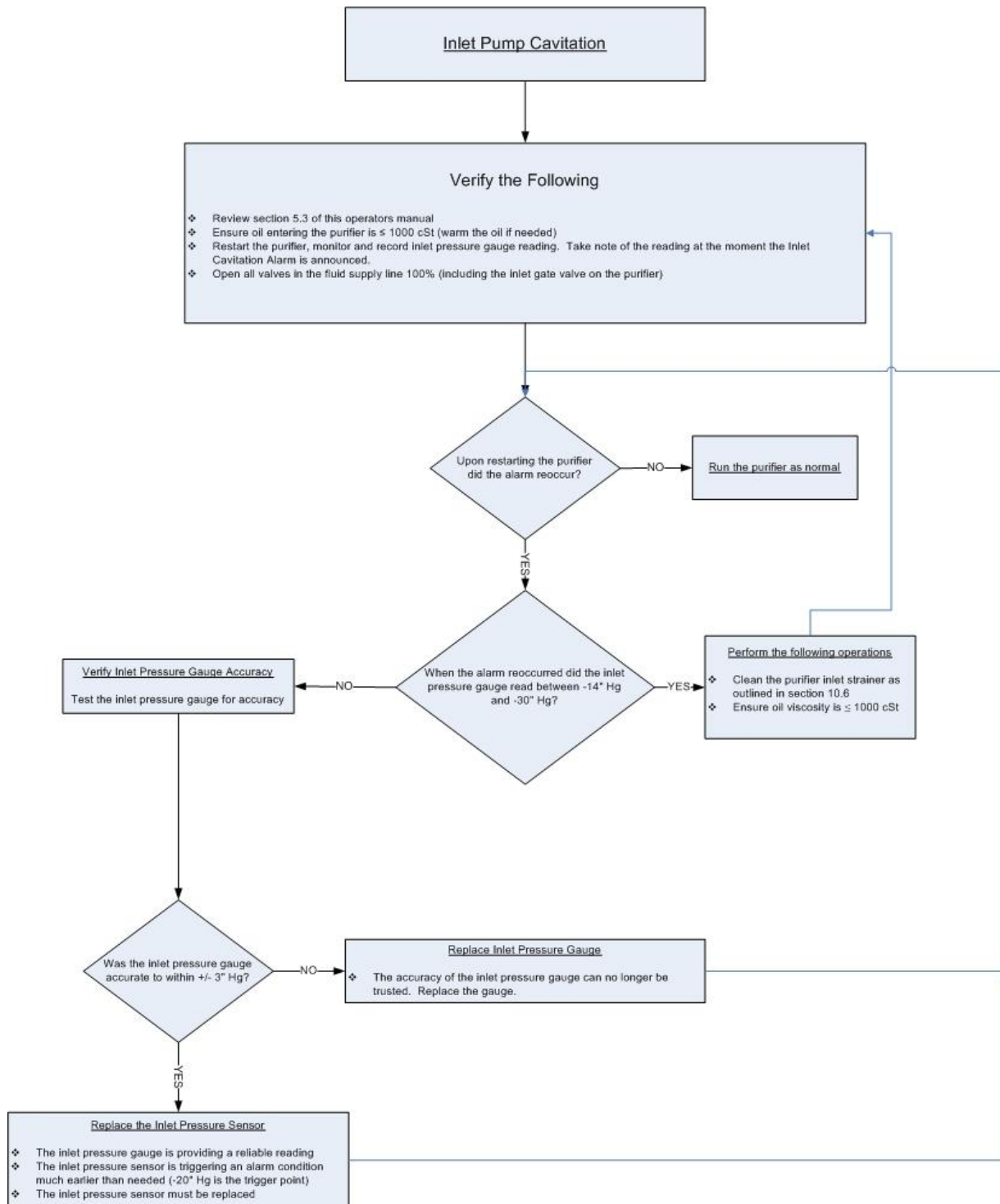

11.6 Major Alarm #6: Change Exhaust Coalescer



Downstream of the vacuum pump resides the vacuum pump exhaust air coalescer. The purifier is fitted with an analog gauge and a pressure sensor to detect high pressure conditions upstream of the coalescer. The purifier will shutdown and HMI will display “CHANGE EXHAUST COALESCER” alarm when the pressure exceeds the set point of 10 psi (0.7 bar). The pressure sensor is monitored at PLC input I-16 on wire #130.

Possible Causes of this alarm are:

- High line pressure caused by clogged coalescer element
- Operator inadvertently capping/plugging the exhaust air port
- Faulty pressure sensor

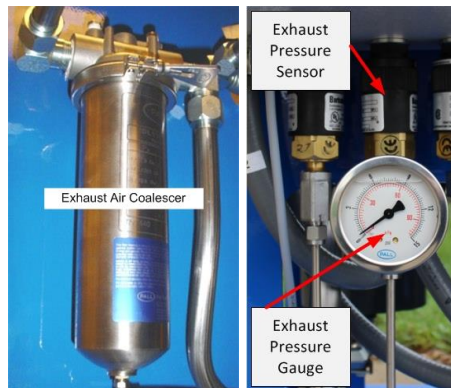

| STEP | ACTION   |
|------|--|
| 1    | Stop the purifier  |
| 2    | Lock out for safety  |
| 3    | Remove the coalescer element from its housing (see section 10.4 for details)   |
| 4    | Re-start purifier, <b>if the alarm does not re-occur</b> install a new coalescer element   |
| 5    | If the alarm re-occurs, verify that no obstructions exist within the tubing connecting the vacuum pump to the coalescer housing              |
| 6    | Re-start the purifier, if the alarm re-occurs, verify that the pressure sensor changes state at approx 10 psi. Replace the sensor if needed. |

11.7 Major Alarm #7: High Tower Level Shutdown



The fluid level within the vacuum tower of the Purifier is monitored by level floats. The fluid level can be viewed in the lower sight glass (shown below). Under normal conditions the fluid level will stay virtually unchanged about half-way up in the sight glass. Conditions may arise when the fluid level is above the expected range, under those conditions the Oil Purifier will issue a “HIGH TOWER LEVEL SHUTDOWN” alarm.

Possible causes of this alarm are:

- Closed valve in fluid discharge line (between purifier and reservoir)
- High backpressure in fluid discharge line resulting from head pressure or other obstruction
- Tower vacuum level too high (fluid pump can not pull fluid out of the tower)
- Fluid viscosity increase resulting from temperature decrease
- Broken or obscured outlet check valve (not opening fully)
- Suction leak or obstruction at the inlet to the purifiers discharge pump
- Coupling failure or broken pump shaft between discharge pump and motor
- Damaged or failed outlet pump relief valve
- Large amount of “foam” in the fluid entering the discharge pump

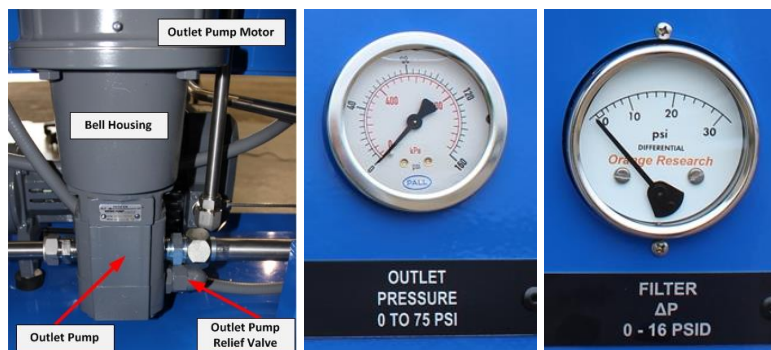

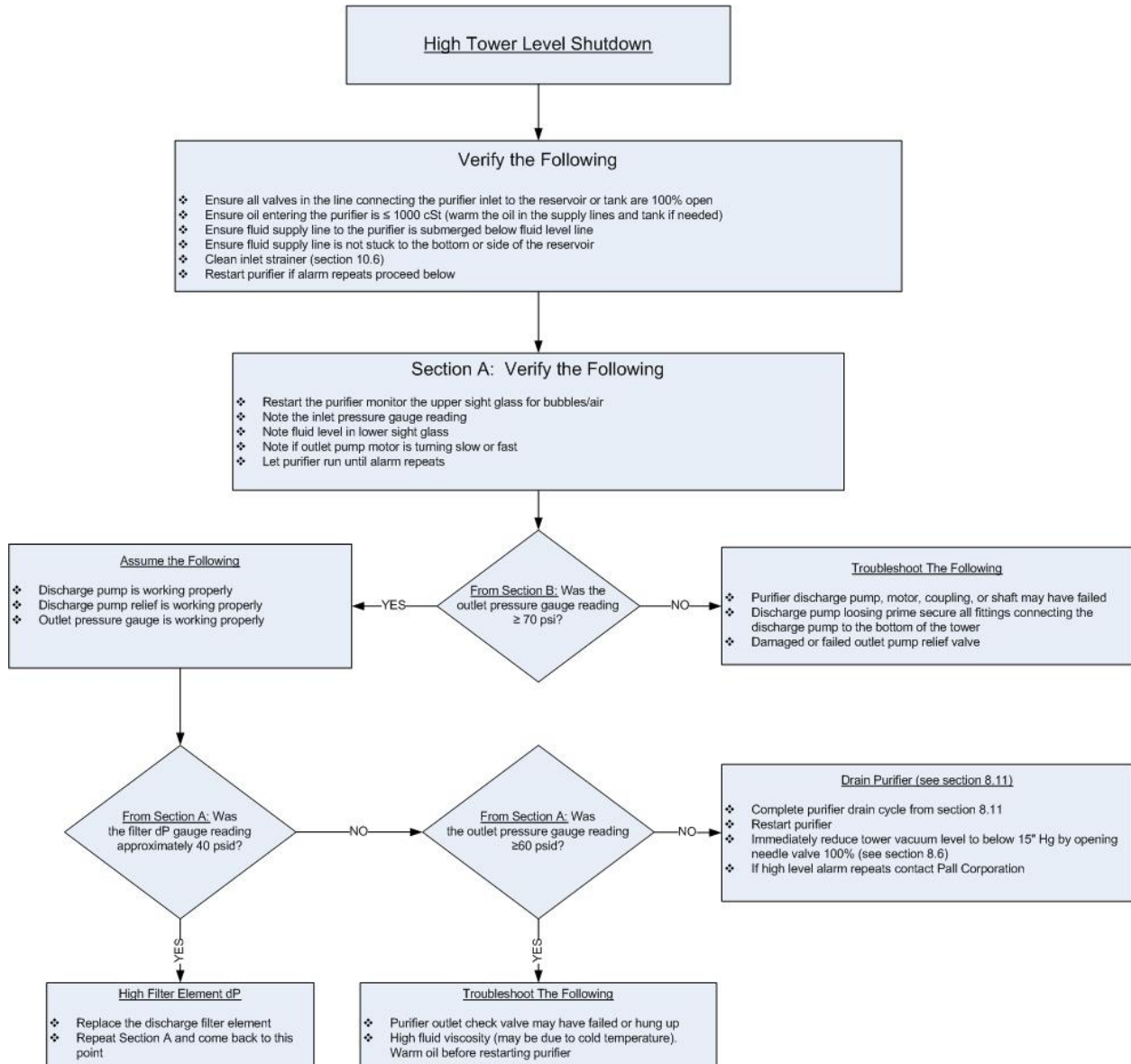

11.8 Major Alarm #8: Low Tower Level Shutdown



The fluid level within the vacuum tower of the Purifier is monitored by level floats. The fluid level can be viewed in the lower sight glass (shown below). Under normal conditions the fluid level will stay virtually unchanged about half-way up in the sight glass. Conditions may arise when the fluid level is below the expected range; under those conditions the Oil Purifier will issue a “LOW TOWER LEVEL SHUTDOWN” alarm and the purifier will shutdown.

Possible causes of this alarm are:

- Fluid is too viscous  $\geq 1000$  cSt (warm the fluid in the supply line and tank)
- Air leak on inlet line (loose fittings, inlet line not submerged in tank)
- Large amount of “foam” in the fluid entering the purifier inlet pump
- Coupling failure or broken shaft between inlet pump and motor
- Broken or obscured inlet check valve (not opening fully)
- Failed pressure relief valve on inlet fluid pump

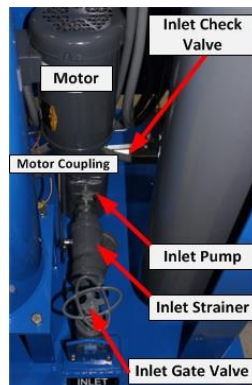

## Low Tower Level Shutdown

### Verify the Following

- ❖ Ensure all valves in the line connecting the purifier inlet to the reservoir or tank are 100% open
- ❖ Ensure oil entering the purifier is  $\leq 1000$  cSt (warm the oil in the supply lines and tank if needed)
- ❖ Ensure fluid supply line to the purifier is submerged below fluid level line
- ❖ Ensure fluid supply line is not stuck to the bottom or side of the reservoir
- ❖ Clean inlet strainer (section 10.6)
- ❖ Restart purifier if alarm repeats proceed below

### Section A: Verify the Following

- ❖ Restart the purifier monitor the upper sight glass for bubbles/air
- ❖ Note the inlet pressure gauge reading
- ❖ Note fluid level in lower sight glass
- ❖ Note if outlet pump motor is turning slow or fast
- ❖ Let purifier run until alarm repeats

### Troubleshoot the Following

- ❖ Possible pump / motor coupling failure
- ❖ Possible pump shaft failure
- ❖ Possible inlet check valve damage or hung up

### Air Leak in the Supply Line

- ❖ A steady stream of air bubbles in the upper sight glass means a leak is present. This leak may reside on-board the purifier.
- ❖ Check and secure the purifier inlet strainer cover
- ❖ Tighten all fittings from the purifier inlet gate valve to the inlet pump.
- ❖ Recheck and secure all fittings connecting the purifier gate valve to the reservoir

Was there a large amount of bubbles seen in the upper sight glass?

← YES

→ NO

Was oil flowing in the upper sight glass?

↑ NO

↓ YES

### Troubleshoot The Following

- ❖ Possible inlet check valve damage or hung up
- ❖ Possible inlet pump relief valve failure or damage



## 11.9 Major Alarm #9: Outlet Pump Motor/Drive Overload



The outlet (discharge) pump of the Oil Purifier has a variable speed and is controlled by a variable frequency drive (VFD). The overload protection for the variable frequency drive is monitored for “trip” conditions at all times. Whenever the purifier is energized the PLC monitors input I-12 (wire #126) for a 24 VDC acknowledgement signal. If the signal drops for any reason the “OUTLET PUMP MOTOR DRIVE OVERLOAD” alarm will be announced on the HMI screen and the purifier will shutdown.

Possible causes of this alarm are:

- High oil viscosity causing the VFD to draw too much current
- Loose wiring
- Failed 24 VDC power supply
- Faulty VFD

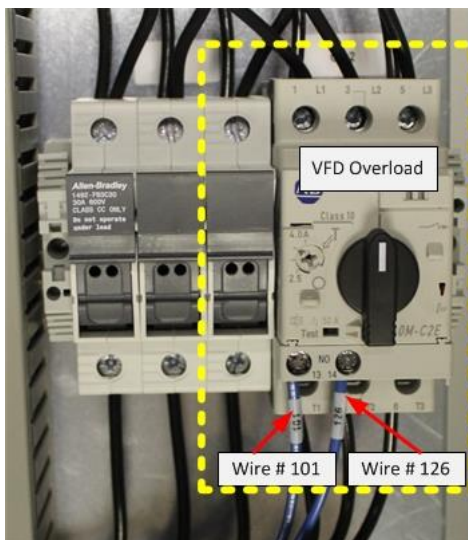

Outlet Pump Motor Drive Overload



24 VDC Power Supply



Variable Frequency Drive

| STEP | ACTION   |
|------|--|
| 1    | Stop the purifier and depressurize   |
| 2    | Lock out for safety  |
| 3    | Ensure oil viscosity is below 1000 cSt   |
| 4    | Ensure 3 phase wires entering the top of the overload are secure and continuous up to the main disconnect. Secure connections as needed  |
| 5    | Test continuity of 3 phase wires leaving the bottom of the overload traveling to the VFD. Secure connections as needed.  |
| 6    | Test and repair continuity of wire #126 from the overload (shown above) and input I-12 at the PLC. Wire should be continuous; repair as needed.  |
| 7    | Test and repair the continuity of wire #101 at the overload and wire #101 at the 24VDC supply.   |
| 8    | After completing the above energize the purifier but do not start. Carefully verify 24 VDC on wire #101 at the inlet motor contactor. Replace the 24 VDC supply if no voltage is detected. |
| 9    | Re-start the purifier  |
| 10   | If alarm repeats contact Pall Corporation  |

**11.10 Major Alarm #10: Inlet Pump Motor Overload**

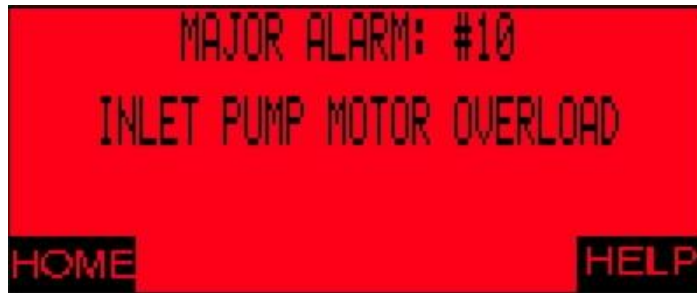

The inlet fluid pump of the Oil Purifier is protected against current overdraw. Whenever the purifier is energized the PLC monitors input I-07 (wire #121) for a 24 VDC signal. If the signal presents itself for any reason the “INLET PUMP MOTOR OVERLOAD” alarm will be announced on the HMI screen and the purifier will shutdown.

Possible causes of this alarm are:

- Inlet pump motor has drawn too much current and “tripped” overload
- Misadjusted current setting on the overload
- Loose wiring
- Failed 24 VDC power supply

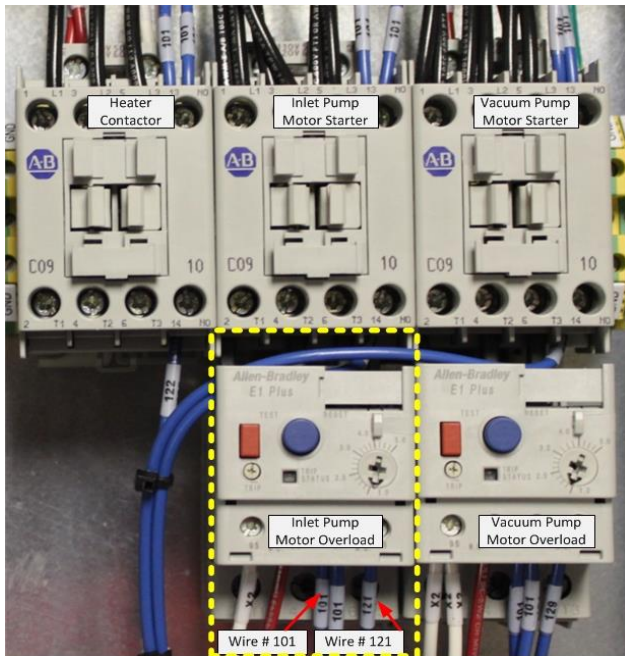

Inlet Pump Motor Overload



24 VDC Power Supply

| STEP | ACTION   |
|------|--|
| 1    | Stop the purifier and depressurize   |
| 2    | Lock out for safety  |
| 3    | Inspect the overload for a “trip” condition. If the overload has tripped there will be a yellow flag in the trip window. To reset the overload, press in the overload reset button.            |
| 4    | <b>Caution – Inspect only:</b> Inspect (note) the setting of the current adjustment wheel located on the overload. The amperage setting is factory set and should not be adjusted.             |
| 5    | Test continuity of wire #121 from the overload (shown above) and input I-07 at the PLC. Wire should be continuous; repair as needed.   |
| 6    | Test continuity of wire #101 at the overload and wire #101 at the 24VDC supply. Wire should be continuous; repair as needed.   |
| 7    | After completing the above energize the purifier but do not start. Carefully verify 24 VDC on wire #101 at the inlet pump motor overload. Replace the 24 VDC supply if no voltage is detected. |
| 8    | Measure the current draw at the motor. Replace motor if current draw exceeds the value stated on the motor name plate.   |
| 9    | Contact Pall Corporation if additional help is needed.   |
|      |  |

## 11.11 Major Alarm #11: Vacuum Pump Motor Overload

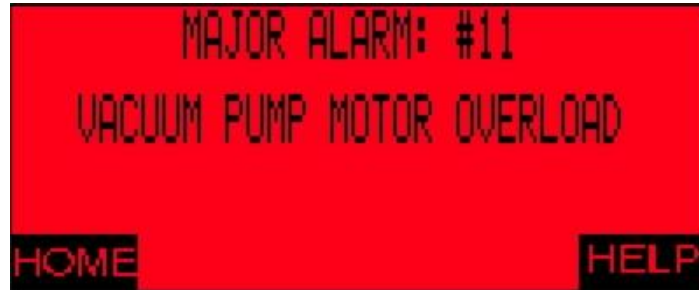

The vacuum pump of the Oil Purifier is protected against current overdraw. Whenever the purifier is energized the PLC monitors input IN15 (wire #129) for a 24 VDC signal. If the signal presents itself for any reason the “VACUUM PUMP MOTOR OVERLOAD” alarm will be announced on the HMI screen and the purifier will shutdown.

Possible causes of this alarm are:

- Vacuum pump motor has drawn too much current and “tripped” overload
- Misadjusted current setting on the overload
- Loose wiring
- Failed 24 VDC power supply
- Failed vacuum pump motor

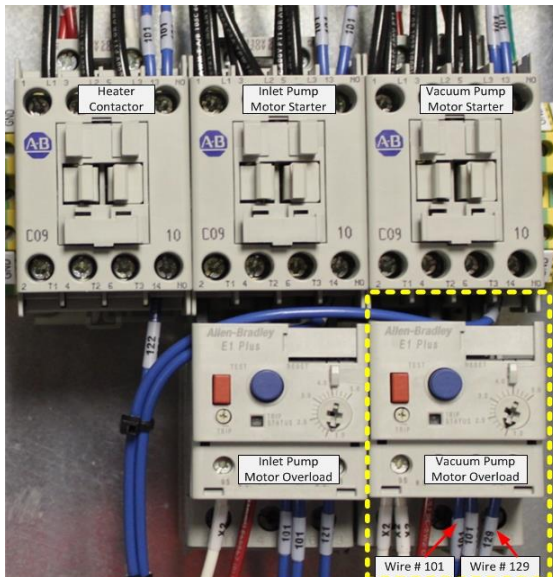

Vacuum Pump Motor Overload



24 VDC Power Supply

| STEP | ACTION   |
|------|--|
| 1    | Stop the purifier and depressurize   |
| 2    | Lock out for safety  |
| 3    | Inspect the overload for a “trip” condition. If the overload has tripped there will be a yellow flag in the trip window. To reset the overload, press in the overload reset button.            |
| 4    | <b>Caution – Inspect only:</b> Inspect (note) the setting of the current adjustment wheel located on the overload. The amperage setting is factory set and should not be adjusted.             |
| 5    | Test continuity of wire #129 from the overload (shown above) and input I-15 at the PLC. Wire should be continuous, repair as needed.   |
| 6    | Test continuity of wire #101 at the overload and wire #101 at the 24VDC supply. Wire should be continuous, repair as needed.   |
| 7    | After completing the above energize the purifier but do not start. Carefully verify 24 VDC on wire #101 at the inlet pump motor overload. Replace the 24 VDC supply if no voltage is detected. |
| 8    | Measure the current draw at the motor. Replace motor if current draw exceeds the value stated on the motor name plate.   |
| 9    | Contact Pall Corporation if additional help is needed.   |
|      |  |

11.12 Major Alarm #12: Dirty Filter Warning – Dirty Filter Shutdown



The status of the discharge filter is constantly monitored for elevated differential pressure (dP) conditions. Whenever the purifier is energized the PLC monitors input I-13 (wire #127) for a 24 VDC signal. If the signal drops the purifier will begin the two-part filter alarm sequence.

Part 1: “DIRTY FILTER WARNING” – when the dP across the filter element exceeds the set point of 16 psid the purifier issues a dirty filter warning and begin a 24-hour countdown timer. The purifier will continue to run. If the high dP condition continues for 24 hours, the purifier will shut down. **Note:** Elevated fluid viscosity due to cold oil may trigger the dP warning. The warning may go away if the oil warms and the viscosity drops.

Part 2: “DIRTY FILTER SHUTDOWN” – When the countdown timer from part one reaches “0” and the elevated dP condition still remains, the purifier will shut down and issue an alarm on the HMI (shown above).

Possible causes of this alarm are:

- Plugged or obscured filter element
- High-viscosity fluid causing elevated dP
- Loose wiring
- Failed dP gauge
- Failed 24 VDC power supply



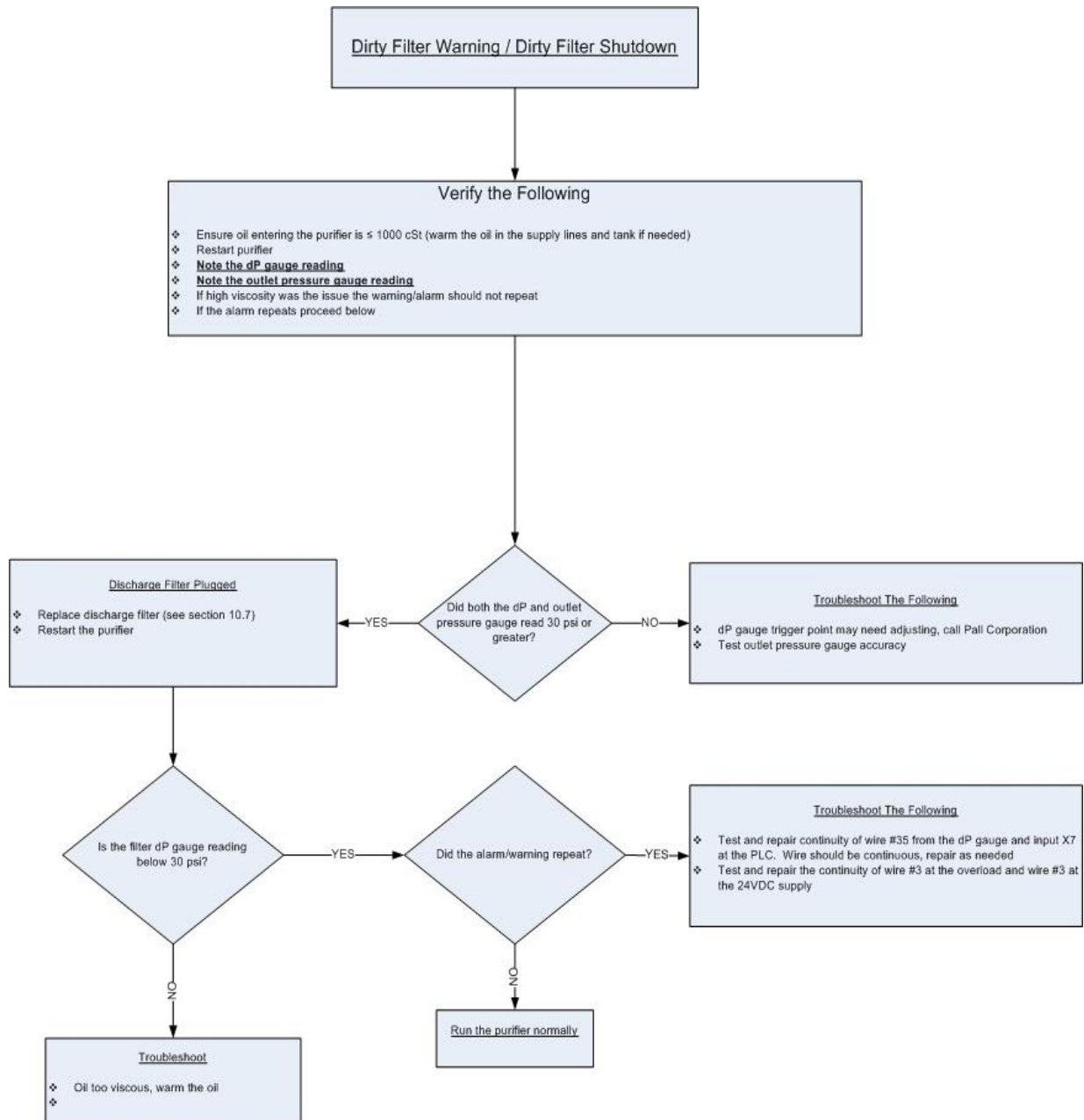

11.13 Major Alarm #13: Tower Fluid Level Sensor Signal Loss



The fluid level sensor inside the purifier vacuum tower continuously sends an analog signal to the PLC’s analog input card on input CI-0 on wire #200. If the signal drops completely or goes below a predetermined threshold the “TOWER FLUID LEVEL SENSOR SIGNAL LOSS” alarm will be announced on the HMI screen and the purifier will shutdown.

Possible causes of this alarm are:

- Failed or damaged 24 VDC power supply
- Faulty wiring
- Damaged float sensor

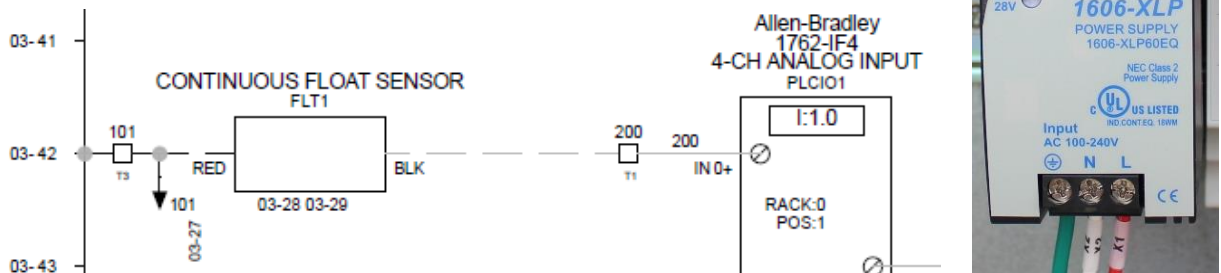



11.14 Major Alarm #14: Outlet Pump Motor Drive Faults



The outlet fluid pump motor of the purifier is controlled by a variable frequency drive (VFD). If a fault condition occurs within the VFD the purifiers HMI will issue the “OUTLET PUMP MOTOR DRIVE FAULT <###>” alarm. The HMI will display the specific fault number. If this alarm occurs the operator should note the fault number and contact Pall Corporation.

11.15 Major Alarm #15: Outlet Pump Motor Drive Comm. Loss



The Oil Purifier monitors the communication between the PLC and the variable frequency drive (VFD). If loss of communication occurs between the PLC and VFD the purifiers HMI will issue the “OUTLET PUMP MOTOR DRIVE COMM. LOSS” alarm and the purifier will shut down.

Possible causes of this alarm are:

- Damaged or unplugged comms cable

Power down the purifier before proceeding. Check and secure the comms cable at the PLC and also where it terminates at the VFD. Replace the cable if needed.

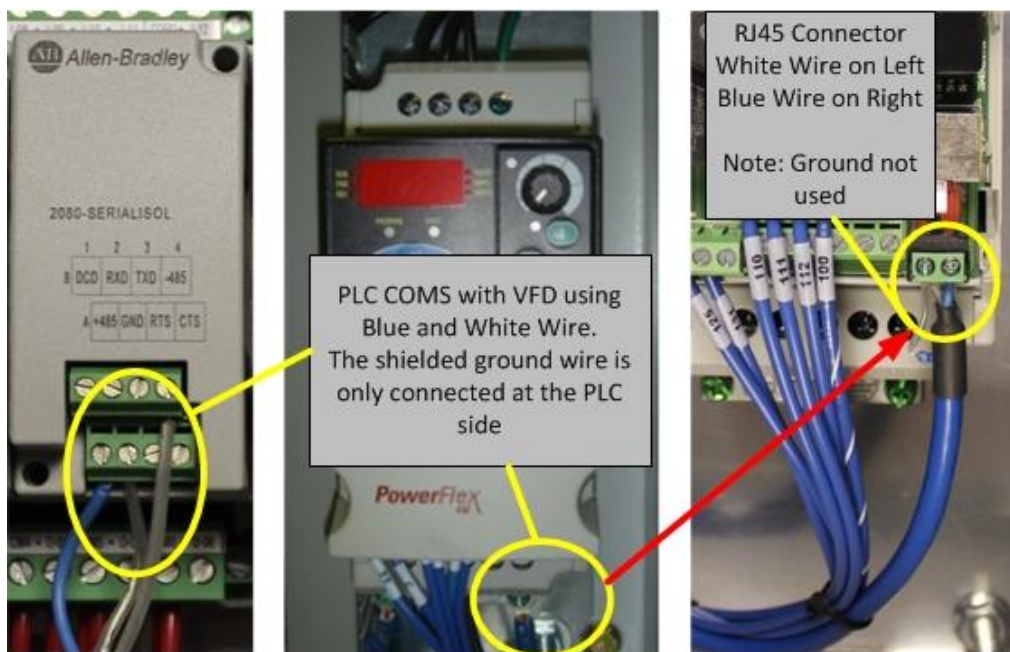

Minor Alarms

**11.101 Minor Alarm #101: Heater Thermocouple Signal Loss**

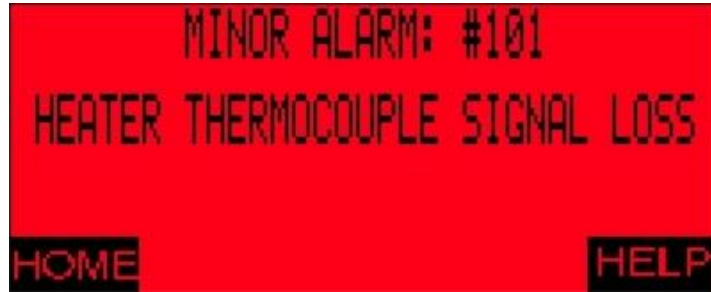

The Oil Purifier monitors the communication between the PLC and the heater thermocouple. If loss of communication occurs between the PLC and thermocouple the purifiers HMI will issue the “HEATER THERMOCOUPLE SIGNAL LOSS” alarm.

Possible causes of this alarm are:

- The heater thermocouple transmitter has failed
- The wiring from the transmitter to the PLC analog card has shorted or is open
- Channel #1 (CI-1) of the analog card has failed or is damaged

This alarm is most likely **not** caused by a failed or damaged thermocouple.

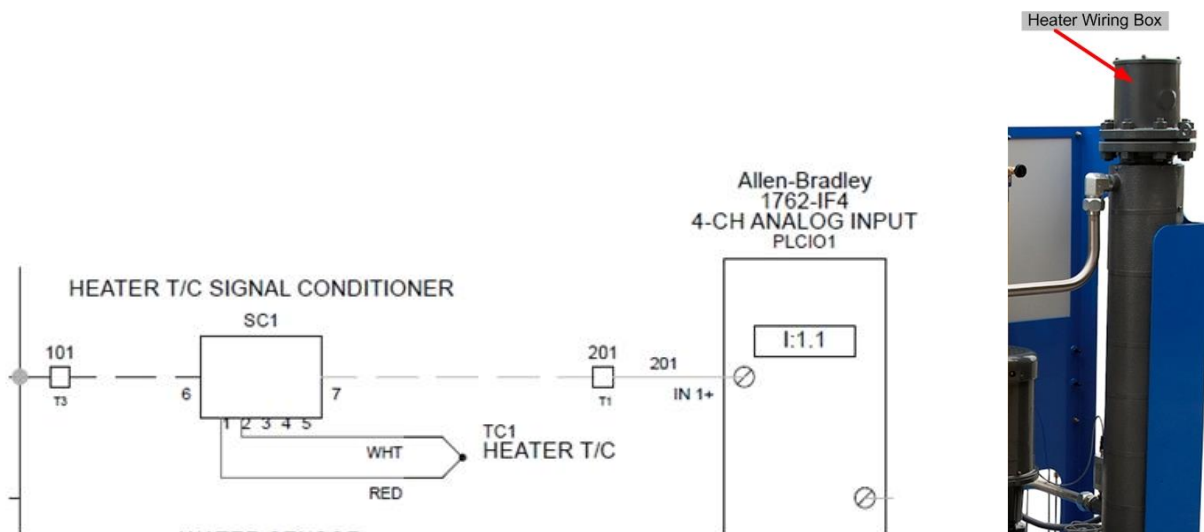



Analog Card

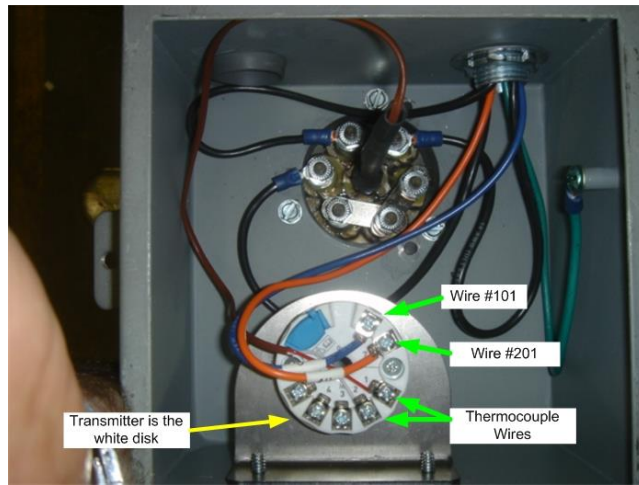

Inside view of heater wiring box

| STEP | ACTION   |
|------|--|
| 1    | Stop the purifier and depressurize   |
| 2    | Lock out for safety  |
| 3    | Locate and open the heater wiring box  |
| 4    | Test and repair continuity of wire #201 from the transmitter (shown above) and input to the PLC's analog card at channel #1 (CI-1). Wire should be continuous, repair as needed. |
| 5    | Test and repair the continuity of wire #101 at the transmitter and wire #101 at the 24VDC supply.  |
| 6    | After completing the above energize the purifier but do not start. Carefully verify 24 VDC on wire #101 at the transmitter. Replace the 24 VDC supply if no voltage is detected. |
| 7    | At the PLC's analog card, measure the milliamp output of the transmitter on wire # 201. If output is less than 2 mA replace the transmitter.                                     |

**11.102 Minor Alarm #102: High Oil Temperature at Water Sensor**



It is common industry practice to never allow oil reservoir temperatures to exceed 160°F (71°C). The Purifier is preprogrammed to issue the “HIGH OIL TEMPERATURE AT WATER SENSOR ALARM” if the temperature of the oil entering the purifier exceeds 160°F (71°C). The entering oil temperature is measured by the on board water sensor located near the purifiers inlet. The alarm trigger point can be adjusted by the user, see section 12 of this manual for details.

**11.103 Minor Alarm #103: High Water Saturation**

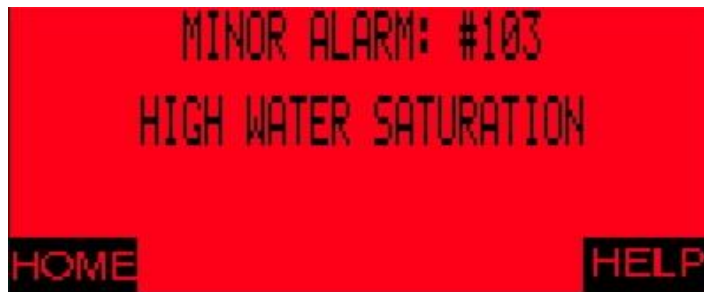

Conditions may develop in which the water content in the reservoir or tank will spike high. The cause of the water spike can be attributed to many factors which will not be discussed within this IOM. The Oil Purifier is equipped with a water sensor will measure the dissolved water content of the fluid entering the purifier, upstream of the heater. The Purifier is factory programmed to issue to issue the “HIGH WATER SATURATION ALARM” if the dissolved water content at the inlet of the Purifier exceeds 90% saturation. The alarm trigger point can be adjusted, see section 12 of this manual for details.

Anytime the dissolved water content approaches or exceeds 90% saturation the user should take immediate action to pinpoint and arrest the source of the water ingress. The High Water Saturation Alarm should be taken seriously and immediate action must be taken to reduce the source of water ingress.

11.104 Minor Alarm #104: Heater Contactor Failure



The heater contactor for the Oil Purifier is monitored for proper operation at all times. This alarm is monitored by auxiliary contacts on the heater contactor. The auxiliary contacts are wired normally closed, wire #101 carries 24 VDC and wire #122 carries the 24 VDC signal back to the PLC to input IN8. When the PLC engages the heater it looks for a 24 VDC acknowledgment signal on wire #122. If the signal is not detected within 1 second the “HEATER CONTACTOR FAILURE” alarm will be announced on the HMI screen. The purifier will continue to run under this alarm condition.

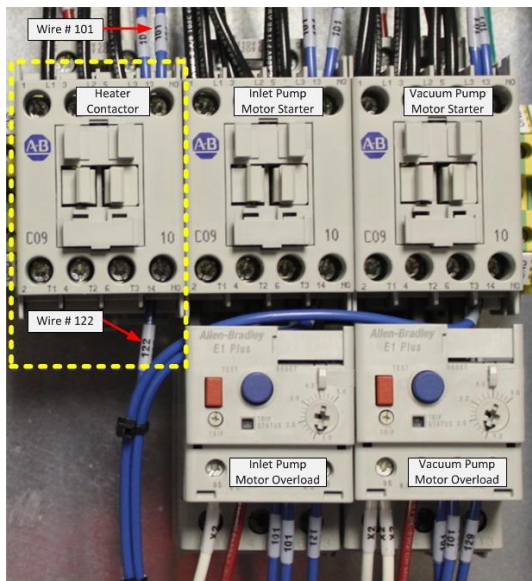

Heater Contactor



24VDC Power Supply



FU1 Fuse Bank

| <b>STEP</b> | <b>ACTION</b>   |
|-------------|---|
| 1           | Stop the purifier and depressurize  |
| 2           | Lock out for safety   |
| 3           | Verify the integrity of Fuse FU1, replace if needed.  |
| 4           | Test and repair continuity of wire #122 from the contactor (shown above) and input IN8 at the PLC. Wire should be continuous, repair as needed.   |
| 5           | Ensure the voltage supplied to the purifier is off and locked out for safety. Manually press in the contactor, simultaneously test continuity of wire #122 & #101 (shown above). Circuit should be continuous when contactor is pressed in. Replace contactor if continuity test fails. |
| 6           | Test and repair the continuity of wire #101 at the contactor and wire #101 at the 24VDC supply.   |
| 7           | After completing the above, energize the purifier but do not start. Carefully verify 24 VDC on wire #101 at the heater contactor. Replace the 24 VDC supply if no voltage is detected.  |
| 8           | Re-start the purifier   |

## Warnings

### 11.201 Warning #201: Service Vacuum Pump Soon



The Oil Purifier will issue a vacuum pump service warning after 8760 hours (365 days) of run time have been logged. The operator should plan on changing the vacuum pump timing gear oil within the next 7 days. Turn to section 10.3 of this manual for instructions on changing the gear oil. After the gear oil is replaced the service timer needs to be reset to 8760 hours. This can be done by pressing the “Reset” button and then typing in 8760 as shown below.

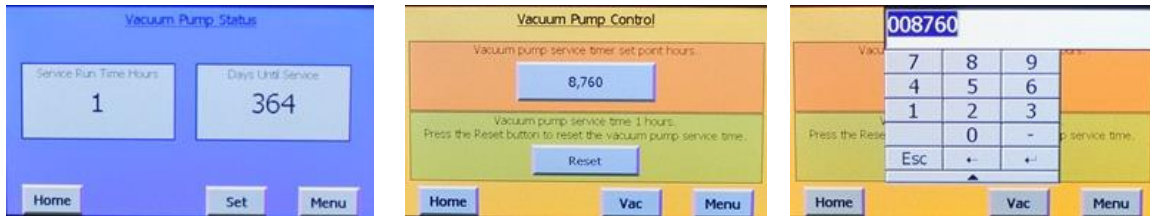

### 11.202 Warning # 202: PLC Battery Low.....Replace Soon



The purifiers PLC used an on board battery. When the battery becomes drained the HMI screen will announce a PLC Battery Low warning. The user should change the battery within 7 days. The battery type is CR2354 lithium ion. For details regarding how to replace the battery, refer to the appendix section corresponding to the PLC which is contained within this operator manual.



**11.203 Warning # 203: Dirty Filter Warning**



When pressure across the main fluid filter reaches approximately 16 psid a dirty filter warning will be displayed on the HMI. Review section 11.12 for details about the entire filter alarm sequence.

**11.204 Not Used**

**11.205 Warning # 205: Water Saturation Probe Signal Loss**



The water sensor onboard the purifier continuously sends an analog signal to the PLC on wires #202 & #203. If the signal drops completely or goes below a predetermined threshold the “WATER SATURATION PROBE SIGNAL LOSS” warning will be displayed on the HMI screen. The operator should make sure the connector is securely plugged into the back of the water sensor and that continuity exists on wire numbers 202 & 203 between the water sensor and PLC analog card termination points. Contact Pall Corporation for further instructions.

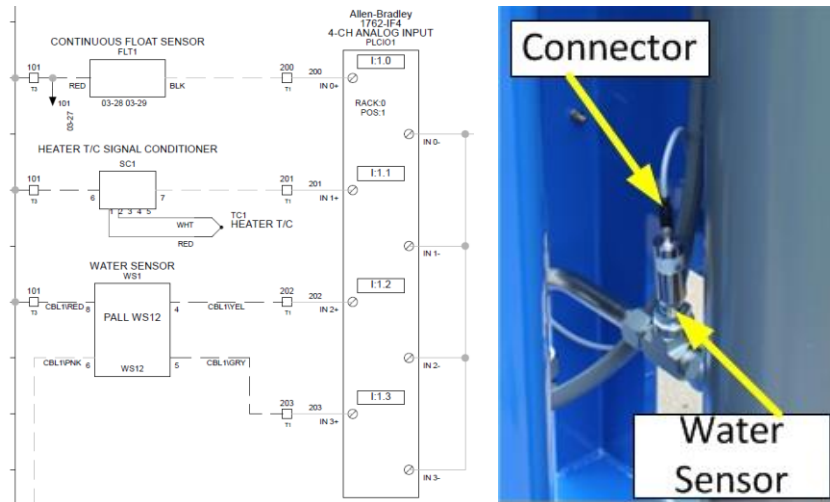

11.206 Warning #206: Change Vacuum Pump Coalescer Soon

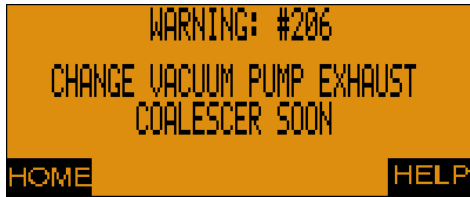

The vacuum pump exhaust coalescer requires changing after 182 days = 4380 hours = 6 months of run time. Approximately 1 week before 6 month have elapsed the purifier will issue a vacuum pump exhaust coalescer service warning. The purifier will continue to run.

| STEP | ACTION  |
|------|---|
| 1    | Stop the purifier and depressurize                            |
| 2    | Change the coalescer: Follow guidelines in section 10.4       |
| 3    | Reset the coalescer timer. Follow guidelines in section 12.13 |

11.301 Heater Not Warming the Oil

Review section 8.8 prior to starting this section. When the heater is energized there should be a noticeable temperature difference between locations A and B (refer to the photo below). If the operator detects no difference in temperature between these tow locations check the

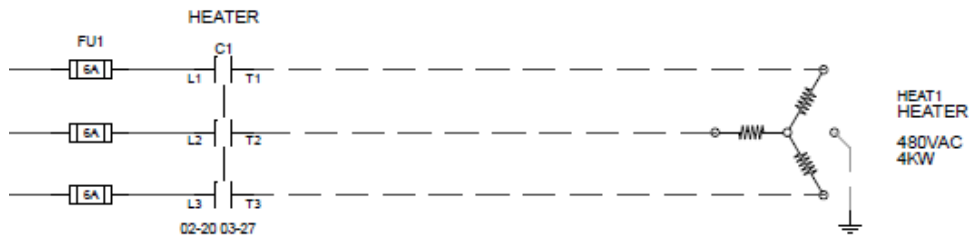

480v circuit shown



Switch Illuminates  
Heater Energized

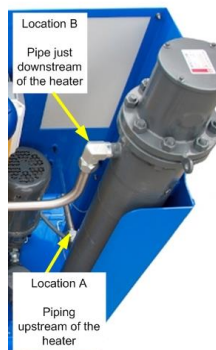

Fuse Bank 1

## 12 HMI SCREENS

The oil purifier is equipped with a human machine interface (HMI). The HMI is used to observe current operating conditions, change set-points, and troubleshoot the purifier.

### 12.1 Home Page

From the home page the operator can navigate to all other screens. The home page displays the temperature and % saturation of the oil entering the purifier upstream of the heater. Pall Corporation has chosen to display this information because it most closely represents the current conditions with the customer reservoir.

F1 to F4 buttons correspond to the items displayed above the buttons. For example pressing F1 will navigate the operator to the system run time screens. Similarly, pressing F4 will call up the menu which lists what each F button corresponds to.



## 12.2 MENU Page – List of screens

When pressing the F4 (MENU) button from the home page the operator will be taken to MENU PAGE. The operator can then open the various screens if desired.

|   |  |
|---|--|
|  | <b>WARNING: DO NOT RESET TIMERS UNLESS REQUIRED!</b>   |
|   | When choosing the installation site, ensure that all hoses and wires are installed in a manner that doesn't present trip hazards to personnel. |
|   | DO NOT RESET TIMER FOR VACUUM PUMP OR COALESCER UNLESS SERVICE WAS JUST PERFORMED.   |



### 12.3 Run Time Screen

The purifiers run time can be viewed by pressing F1 from the home screen.

Total Run Time = total number of run time hours logged by the purifier

Session Run Time = run time hours logged since the machine was last started

To return back to the home page press HOME (F1).

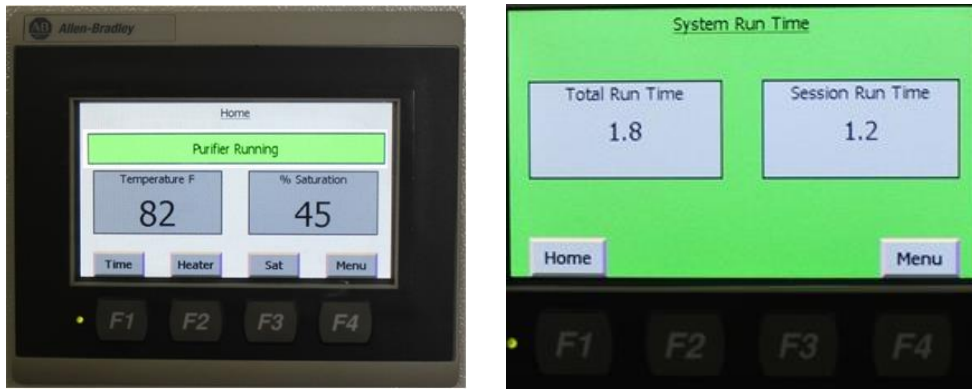

### 12.4 Heater Control Screen

The purifier heater control can be accessed by pressing F2 on the home page.

Heater Control Page 1 shows the heater set-point and the current temperature observed by the on-board thermocouple. From this page the operator can toggle the temperature units from degrees F to degrees C by pressing the F2 button. The operator can adjust the heater set-point by pressing F3 which corresponds to "HEATER" or by pressing the touch screen. To adjust the set-point using the key pad as shown below. To lock in the adjustment press the enter key as shown below. Then return to the home page by pressing F1.

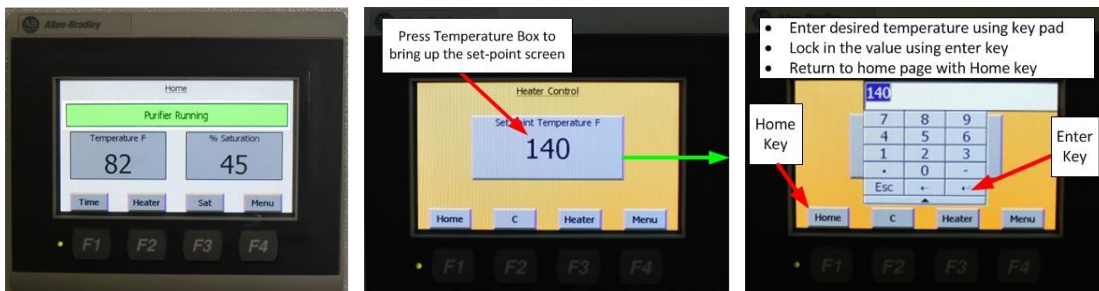

## 12.5 Saturation Sensor (Pall Water Sensor)

The purifier is equipped with a dissolved water sensor located near the inlet of the machine upstream of the heater. The water sensor measures temperature and % saturation of the fluid entering the purifier. The temperature and % saturation measured by the water sensor is displayed on the purifier home page (see below).

The water sensor is factory set to issue a minor alarm when the dissolved water content of the oil entering the purifier exceeds 90% saturation and the temperature of the oil entering the purifier exceeds 160°F (71°C). Review section 11.102 and 11.103 of this manual for alarm details. The trigger points for both alarms can be adjusted by the operator.

The purifier water sensor trigger points can viewed by pressing F3 from the home page.

Adjusting high temperature alarm set-point: The customer can raise or lower the alarm set-point similar to how the values are adjusted in section 12.4.

Adjusting high saturation alarm set-point: The customer can raise or lower the alarm set-point similar to how the values are adjusted in section 12.4. If the user does not want this alarm to come in simply set the alarm value to 100% saturation.

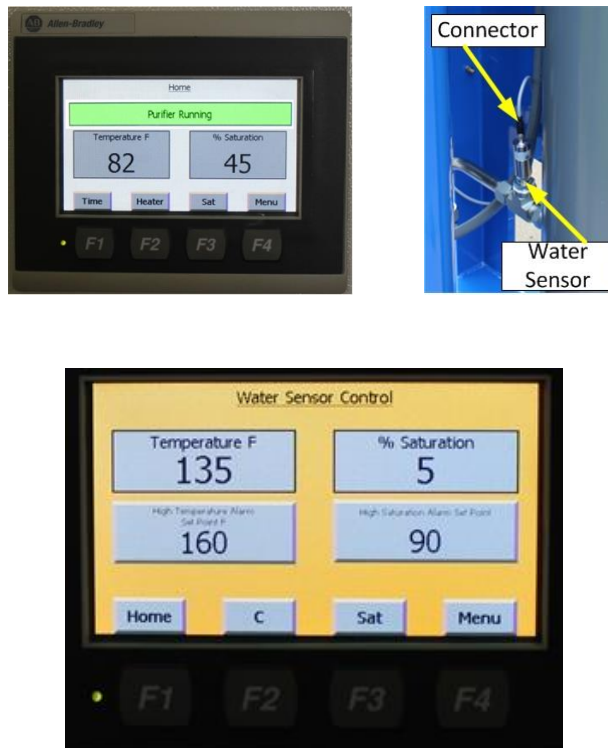

12.6 Filter Status (Main Fluid Filter)

The status of the on-board fluid filter can be viewed by pressing F4 from the home page and then pressing FILTER STATUS.

The purifier is equipped with a premium quality Pall Corporation Athalon® filter element. The dirty filter alarm sequence will begin when the delta P across the filter reaches approximately 16 psid (review section 11.12 and 11.203 for full details). At any point in time the operator can check the status of the discharge filter by navigating to the filter status screens.



When filter dP is below 16 psid the filter status screen will show:



When filter dP reaches 16 psid a Dirty Filter Warning will display & 24 hour countdown will begin



24 hour count down in progress



If the warning condition exists for 24 continuous hours the purifier will shut down.

### 12.7 Tower Level

The level of fluid within the tower along with the VRF command and feedback signals can be viewed from this screen. To access press F4 (Menu) from the home page follow by pressing Tower Level Status.

This screen is very useful for determining overall running status of the purifier. The bar graph on the right side shows the current fluid level in the tower. This is also displayed in numerical form in the LEVEL INCHES box. The VFD command and feedback signals are also displayed here.

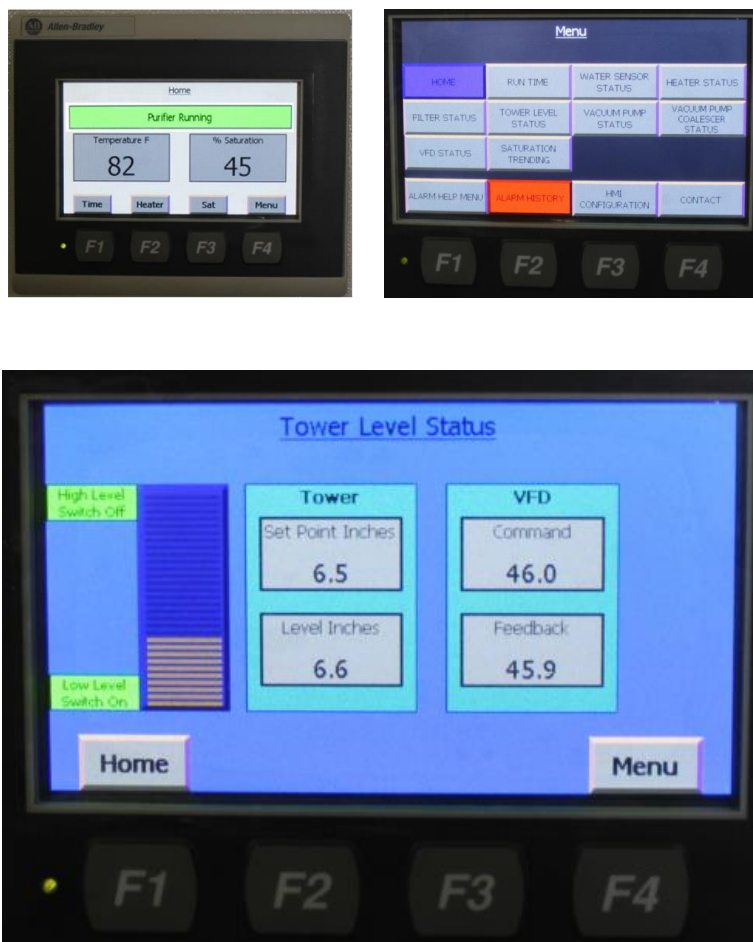



12.8 Vacuum Pump Status

The status of the vacuum pump can be viewed by pressing F4 (Menu) followed by VACUUM PUMP STATUS. The Vacuum Pump Status screen which shows the service run time (in hours) of the vacuum pump and how many more days of run time until the next service. It is important to note that the vacuum pump requires service after 8760 hours of run time (8760 hours equates to 365 days x 24 hours). When approximately 8592 hours of run time have been logged the purifier will issue a vacuum pump service warning (see section 11.201 for details).

**Warning:** The operator can reset the vacuum pump service timer by pressing “RESET”. This should only be done when the vacuum pump timing gear oil has been replaced. Resetting the vacuum pump service timer without replacing the vacuum pump timing gear oil may void the purifier warranty. Always change the oil before pressing the reset button.

If desired the vacuum pump service interval can be adjusted however it is never recommended to adjust the interval higher than 8760 hours. Setting the interval higher than 8760 hours will void the vacuum pump warranty.

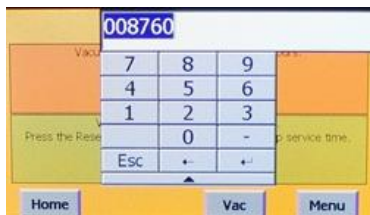
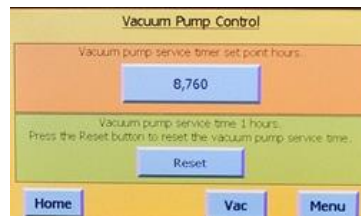

### 12.9 Vacuum Pump Exhaust Coalescer Status

The status of the vacuum pump exhaust coalescer can be viewed by pressing F4 (Menu) followed by VACUUM PUMP COALESCER STATUS. The operator will see the Vacuum Pump Exhaust Coalescer Status screen which shows the service run time (in hours) of the coalescer and how many more days of run time until the next service. It is important to note that the coalescer requires changing after 182 days = 4380 hours = 6 months of run time. Approximately 1 week before 6 month have elapsed the purifier will issue a vacuum pump exhaust coalescer service warning (see section 11.206 for details).

Warning: The operator can reset the service timer by pressing “SET”. This should only be done after the coalescer has been replaced.

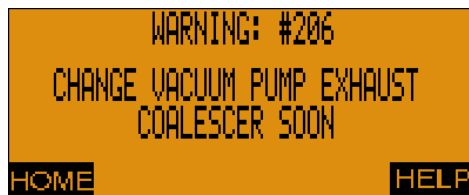
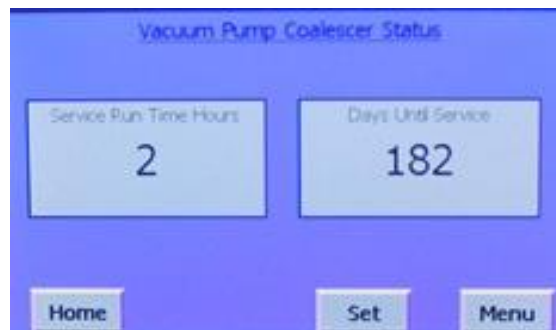

**12.10 VFD Status (Variable Frequency Drive)**

The outlet fluid pump is driven by a variable frequency motor. The operator can view various signals related to the VFD by pressing F4 (Menu) and then VFD STATUS. The operator will then see the VFD command and feedback signals coming from the PLC. The three most recent fault codes will be shown (fault code 1 is the most recent fault).

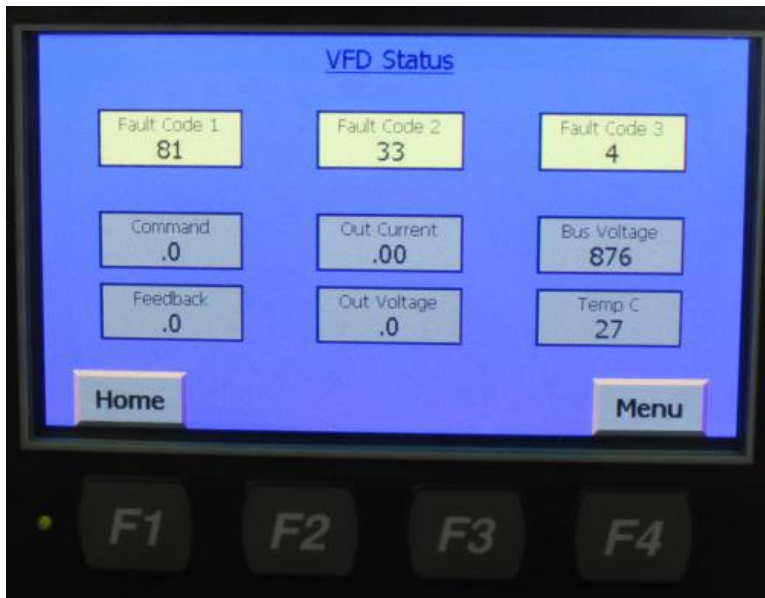

### 12.11 Saturation Trending

All HLP oil purifiers are equipped with the Pall dissolved water sensor which monitors temperature and %water saturation of the oil entering the purifier skid. The HLP is configured with a trending screen to allow the operator to view the previous 48 hours of data collected by the dissolved water sensor. To access the trending screen press the Saturation Trending button on the menu screen.

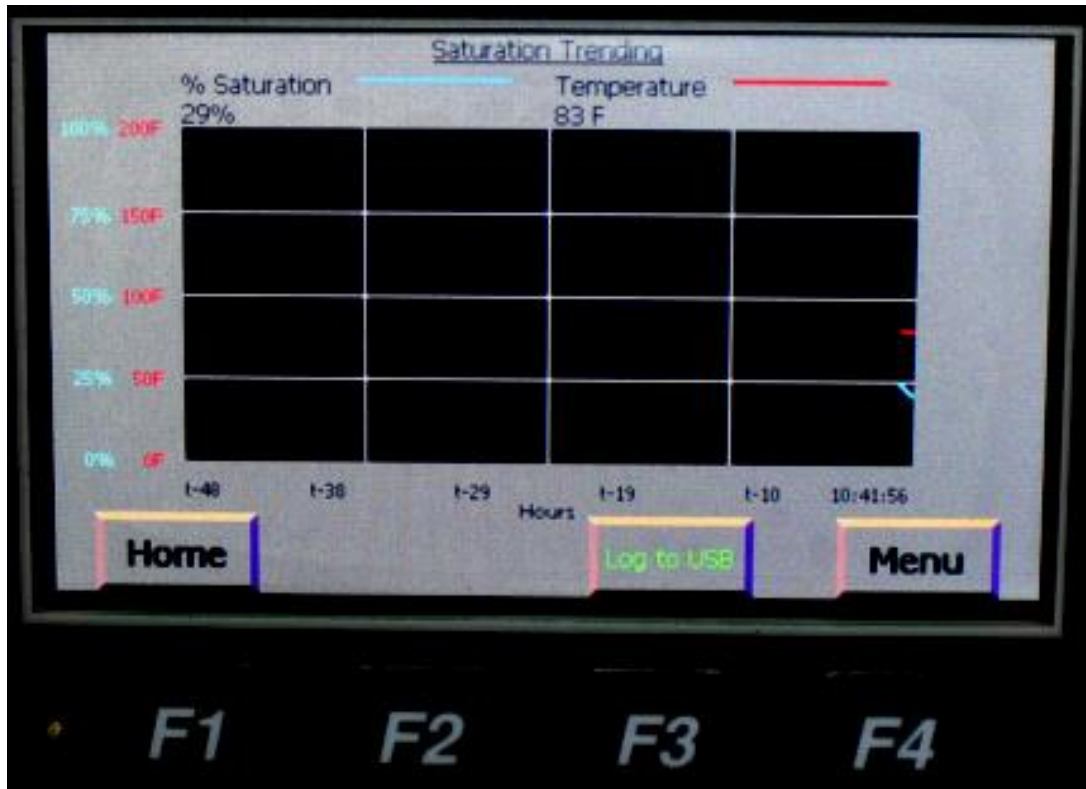

**12.12 Alarm History**

The purifiers PLC will log alarm conditions as they occur. To view the history of alarms which have been logged press F4 (Menu) followed by ALARM HISTORY.

All alarms are date and time stamped. Alarm history cannot be erased. The most recent alarm is at the top of the screen. The operator can toggle between alarms by using the F2 & F3 buttons. The background will turn white as you toggle from one alarm to the other. For each alarm the following information is recorded:

- Occ time: Time when the alarm occurred
- Occ date: Date when the alarm occurred
- Inac time: Time when the alarm was cleared or made inactive
- Inac date: Date when the alarm became inactive

The purifier logs current time and date in the upper left corner of the alarm history screen.



|   |  |
|---|--|
|  | <p><b>WARNING: READ ALL THE WAY THROUGH BEFORE PROCEEDING!</b></p> |
|---|--|

### 12.13 HMI Configuration

During normal purifier usage the operator should avoid accessing the HMI Configuration screens. When accessing the HMI Configuration screen it is not initially obvious how to exit back out. To make a quick exit from the HMI Configuration screen press the GOTO button as shown below.

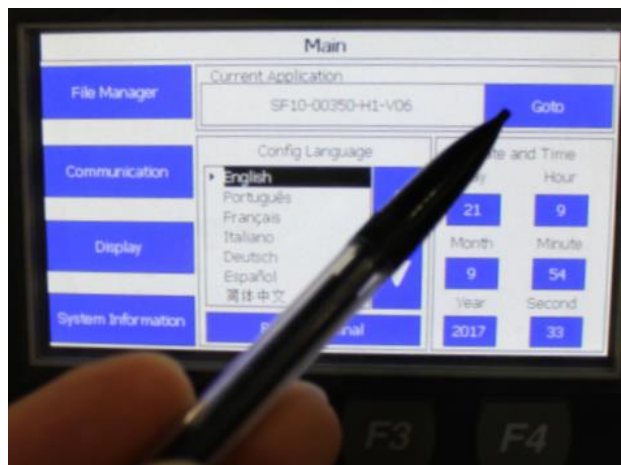
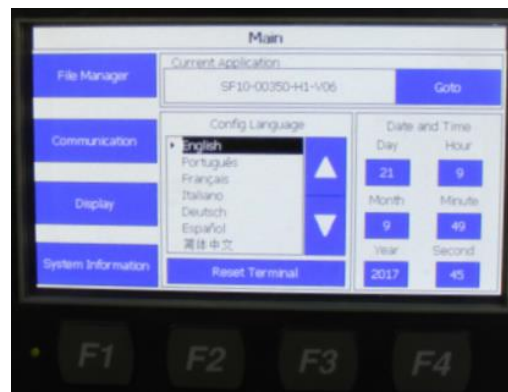

### 12.13.1 Changing Date and Time

Use the HMI Configuration screens to adjust the date and time of the internal clock if needed. The example below shows how to change the hour parameter. Press HMI CONFIGURATION button (Fig #1) to display the next screen (Fig #2). Press the hour button to bring up the dialog box (Fig #3). Type in the desired numbers using the touch pad and press the return key to lock in your choice (Fig #3). In a similar manner additional parameters can be changed. When finished press the GOTO button (Fig #4) to exit out of the HMI Configuration screens.



Fig #1



Fig #2

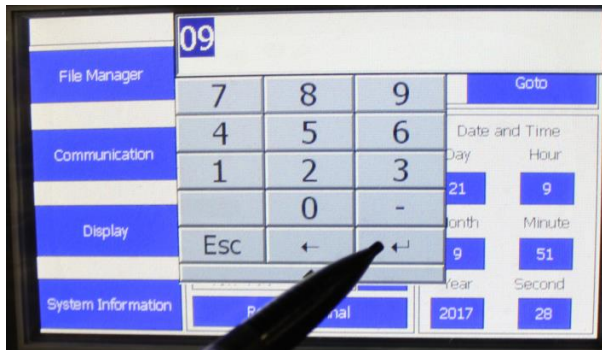

Fig #3

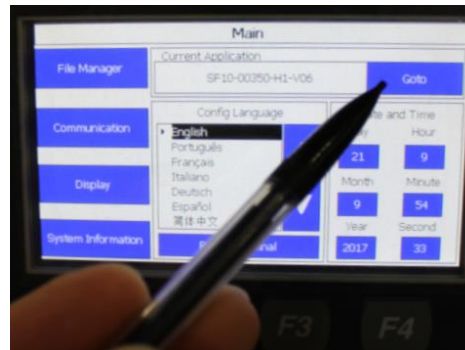

Fig #4

## 13 APPENDIX

### 13.1 Spare Parts List

Below is a list of common spare parts/consumables for the purifier. Some parts have changed during the product life cycle. Customers should also review the unique HLP serial number before ordering spare parts. Contact your local Pall Corporation representative for a price quotation for any needed parts.

Inlet Air Breather (all serial numbers): Pall p/n HC0293SEE5

Inlet Air Breather Indicator (all serial numbers): Pall p/n HC0293D004

Vacuum pump timing gear oil (all serial numbers): Pall p/n 150015001 (1 quart required annually)

Vacuum pump timing gear oil (all serial numbers): Pall p/n 150015002 (1 gallon size)

Discharge filter element: Pall offers the HLP6 with either a 20 inch or 40 inch discharge filter. The 20 inch filter element part number is: UE310 \*\* 20Z

The 40 inch filter element part number is: UE310\*\*40Z

\*\* From the table below select the desired filter micron rating. For example: UE310AP20Z would be a 3 micron 20 inch filter element. Similarly UE310AS40Z would be a 12 micron 40 inch filter element

#### Cleanliness Code Ratings

| Code | $\beta_{x(c) \geq 2000}$<br>per ISO 16889 | CST Rating* |
|------|---|-------------|
| AZ   | 3   | 07/04/01    |
| AP   | 5   | 11/08/03    |
| AN   | 7   | 13/09/04    |
| AS   | 12  | 15/11/06    |
| AT   | 25  | 16/14/08    |

Demisting Pad Kit (serial number dependent):

150054101 – Serial numbers 1246 and higher

F1394319 – Serial numbers 1245 and lower

Coalescer Element (serial number dependent):

PFS1001ZMH – Serial numbers 1246 and higher

OL4C – Serial numbers 1245 and lower



Vacuum Pump (all serial numbers): 10048901  
Level Float Switch Assembly (all serial numbers): 100048501  
Vacuum Pump Breather Kit from section 10.12 (all serial numbers): VLR60BRKIT  
Inlet Pressure Gauge: 400105301  
Tower Vacuum Gauge: 400105401  
Outlet Pressure Gauge: 400105205  
Exhaust Pressure Gauge: 400148101  
Delta Pressure Gauge: 100050101

### 13.2 Purifier Lifting Procedure

|   |  |
|---|--|
|  | <p><b>Use Proper Rigging Procedures!</b></p> <p>Do not attempt to lift the purifier from a single point. Proper rigging procedures should be followed when lifting the purifier. If in doubt contact a rigging professional.</p> |
|---|--|

The Pall Corporation HLP6, HLP10 and HLP22 are designed to be lifted as shown below using proper rigging techniques. Photos below show the HLP22.

